WS2814C

Single Line/256 Grayscale/Four Channel/
Constant Current/LED Driving IC

Main Features

- Output voltage of port R, G, B, W is above 20V, and output voltage of port DIN / DOUT is above 9V.
- With a zener diode built in the chip, 24V, power supplies less than 24V only need to connect resistance to IC VDD feet and don't need an additional zener diode.
- With the signal shaping circuit built in, every pixel will output the signal after the shaping of waveform, which ensures that the distortion of the circuit wave will not accumulate.
- Built-in electrical reset and drop reset circuit.
- The PWM control end can achieve 256 level adjustment with a scanning frequency of 4KHz.
- The serial cascade interface can receive and decode the data through one signal line.
- No circuit is required between any two pixels whose transmission distance is less than 2 meters.
- The color of the light is highly consistent and cost-effective.
- When the refresh rate is 30 frames/s, the number of cascades is more than 1024 points.
- Data transmission speed is up to 800 Kbps.
- With the SOP 8, FSOP 8 package.

Main Application

- Full Color LED string, Full Color LED strip, LED Guardrail Tube.
- LED Point Light Source, LED pixel screen, Special-shaped LED screen.

Product Overview

WS2814C is a four-channel circuit specially driven by LED. The chip contains intelligent digital interface data latch signal shaping amplifier drive circuit, high precision internal oscillator and 20V high voltage programmable current output driver and high precision constant current control module, ensuring that the pixel light on the drive circuit is highly consistent.

Data protocol uses Return Zero code. After the chip power reset, the DIN port receives data transmitted from the controller. The first 32bit data is extracted by the first chip and sent to the internal chip latch. The rest of the data will be transmitted to the pixel of next cascade through the DO port after being shaped and amplified by the internal signal shaping circuit. And the signal is reduced by 32bit each time it passes through a pixel. The chip adopts automatic shaping and transmission technology, so that the cascade number of the pixels is not limited by the signal transmission but only limited by the signal transmission speed.

The data latch inside the chip, based on the received 32bit data, creates different duty cycle at the OTR, OUTG, OUTB, OUTW control ends to control the signals. While waiting for the DIN port inputting RESET signal, all chips send the received data to each segment simultaneously. The chip will receive new data again after the signal ends. After receiving the initial 32-bit data, the chip transmits the data port through the DO port. And the original output of OTR, OUTG, OUTB and OUTW Chip remains the same before the chip receives the RESET code. Only after receiving the Vil RESET code above 280 μ s can the chip output the received 32bitPWM data pulse-width to the OTR, OUTG, OUTB, OUTW pins.

WS2814C

Single Line/256 Grayscale/Four Channel
/Constant Current/LED Driving IC

Lead End Layout

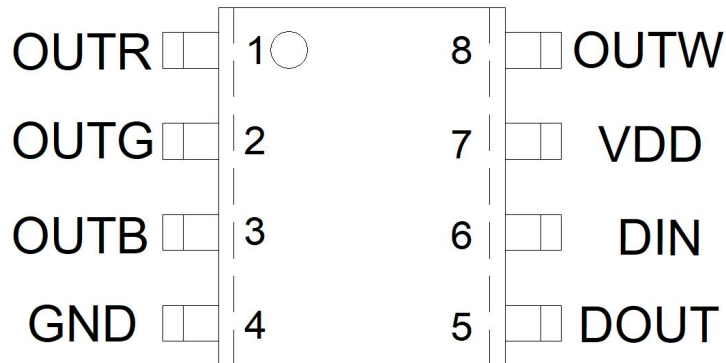

Function of Lead End

Pin Number	Symbol	Name of Pin	Function Description
1	OUTR	LED-Driven Output	RED PWM controlling output
2	OUTG	LED-Driven Output	GREEN PWM controlling output
3	OUTB	LED-Driven Output	BLUE PWM controlling output
4	GND	Ground	Earthing of signal and power supply
5	DOUT	Data Output	Indication of data cascade output
6	DIN	Data Input	Indication of data input
7	VDD		Powered by IC
8	OUTW	LED-Driven Output	WHITE PWM controlling output

Maximum Rated Value ($T_A=25^{\circ}\text{C}$, $V_{SS}=0\text{V}$)

Parameter	Symbol	Scope	Unit
Logical voltage of power supply	V_{DD}	+3.7~+5.3	V
Logical input voltage	V_I	$V_{DD}-0.7\sim V_{DD}+0.7$	V
Input voltage of R、G、B、W port	V_{out}	20	V
Working Temperature	T_{opt}	-40~+85	$^{\circ}\text{C}$
Stock Temperature	T_{stg}	-40~+150	$^{\circ}\text{C}$
Anti-static electricity	ESD	$\cong 4$	KV

WS2814C

Single Line/256 Grayscale/Four Channel/
Constant Current/LED Driving IC

Electric Parameter (T_A=25°C, V_{DD}=4.5~5.5V, V_{SS}=0V)

Parameter	Symbol	Minimum	Typical	Maximum	Unit	Test Condition
R, G, B, W low level input current	I _{OL}	15.5	16.5	17.5	mA	
Low level input current	I _{dout}	10	—	—	mA	V _o =0.4V, D _{OUT}
Input Current	I _I	—	—	±1	μA	V _I =V _{DD} /V _{SS}
High level input	V _{IH}	0.7V _{DD}	—	—	V	D _{IN}
Low level input	V _{IL}	—	—	0.3 V _{DD}	V	D _{IN}
Voltage delay	V _H	—	0.35	—	V	D _{IN}

Characteristics of Switch (T_A=25°C, V_{DD}=4.5~5.5V, V_{SS}=0V)

Parameter	Symbol	Minimum	Typical	Maximum	Unit	Test Condition
Transmission delay	t _{PLZ}	—	—	300	ns	CL=15pF, DIN→DOUT, RL=10KΩ
Decline time	t _{THZ}	—	—	120	μs	CL=300pF, OUTR/OUTG/OUTB/OUTW
Transmission rate	F _{MAX}	600	—	—	Kbps	Duty ratio is 50%
Input capacitance	C _I	—	—	15	pF	—

Time of Data Transmission

T _{0H}	0 code, High level time	220ns~380ns
T _{1H}	1 code, High level time	580ns~1μs
T _{0L}	0 code, Low level time	580ns~1μs
T _{1L}	1 code, Low level time	580ns~1μs
RES	unit of frame, low level time	280μs以上
T _{DATA}	Data cycle	≥1.25us

Waveform of Sequence Signal

Input Code:

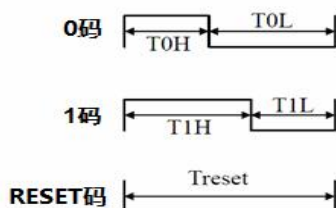

Connection:

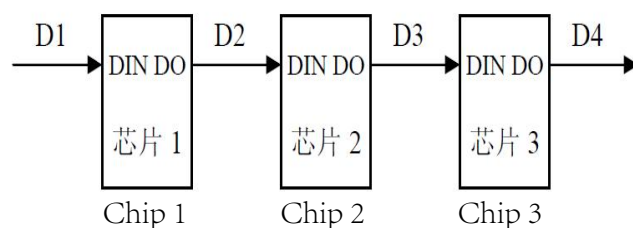

WS2814C

Single Line/256 Grayscale/Four Channel/
Constant Current/LED Driving IC

Method of Data Transmission:

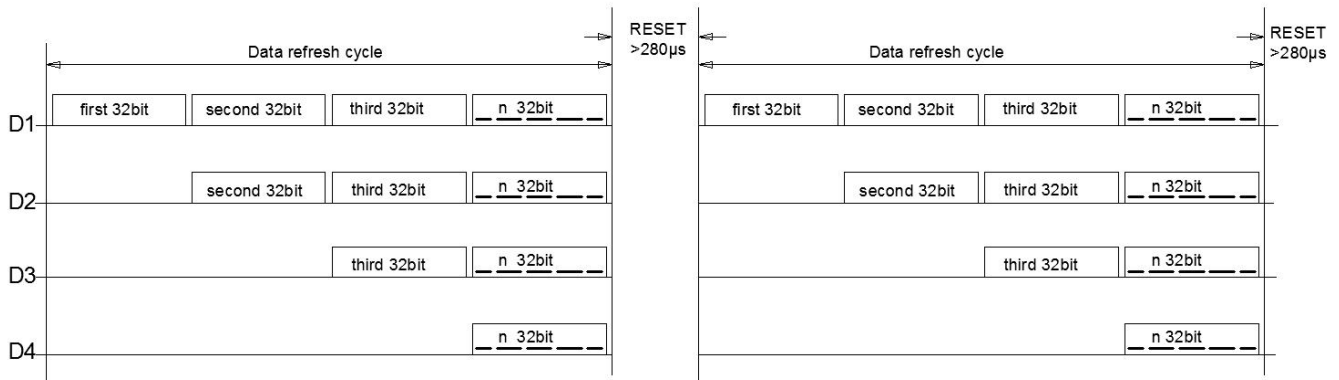

PS. D1 is the data sent by MCU port, D2、D3、D4 are data shaped and transmitted by cascade circuit.

32bit Data Structure

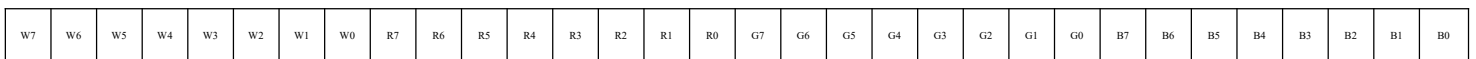

PS. Transmission begins from the top and follows the order of W, R, G, B.

WS2814C

Single Line/256 Grayscale/Four Channel/
Constant Current/LED Driving IC

Typically Applied Circuit

1. 5V供电应用参考电路（每通道带1颗LED）：5V power supply application reference circuit (each channel with 1 LED) :

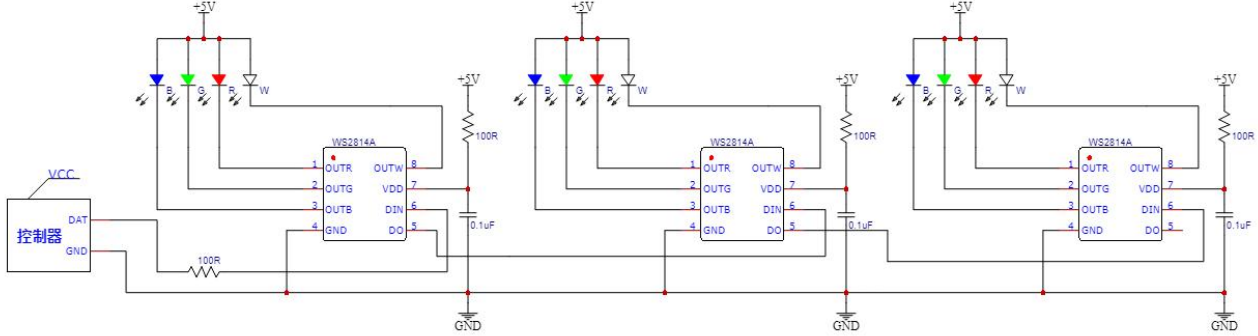

2. 12V供电应用参考电路（每通道带3颗LED）：12V power supply application reference circuit (each channel with 3 LED) :

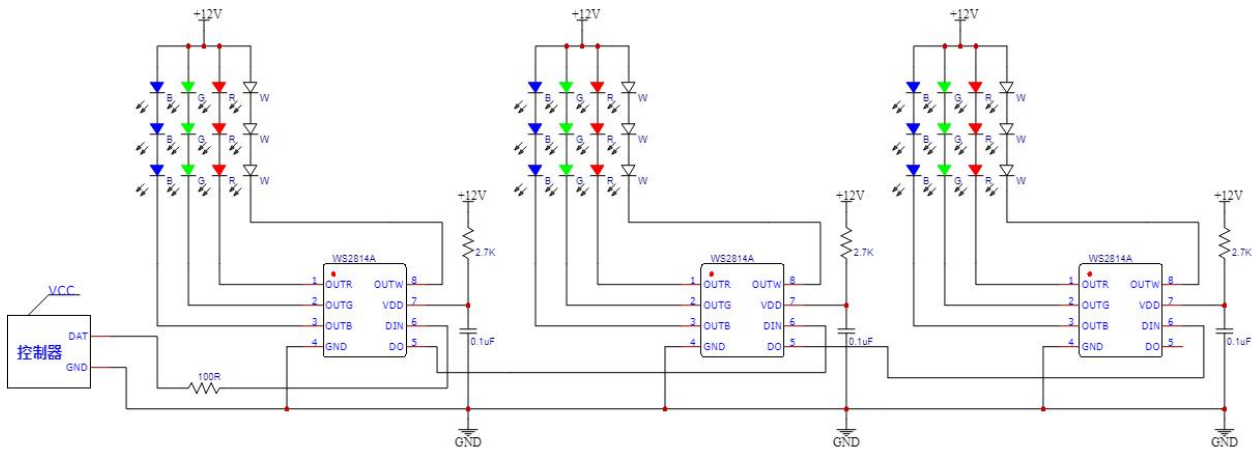

3. 24V供电应用参考电路（每通道带6颗LED）：24V power supply application reference circuit (each channel with 6 LED) :

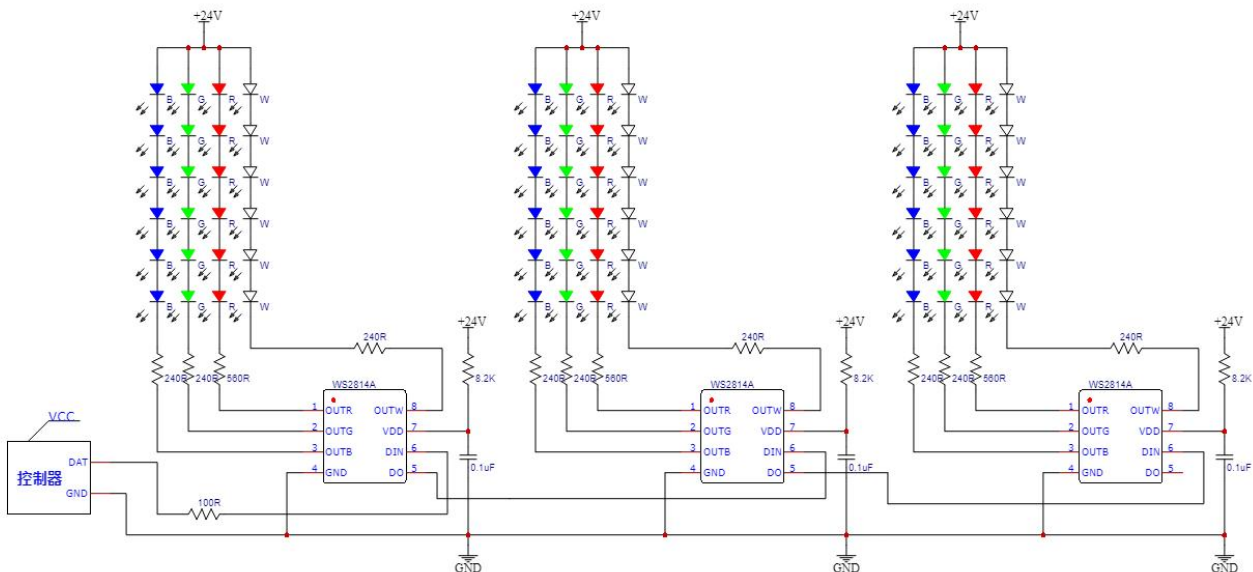

WS2814C

Single Line/256 Grayscale/Four Channel/Constant Current/LED Driving IC

Package and Parameter

- SOP8 Package

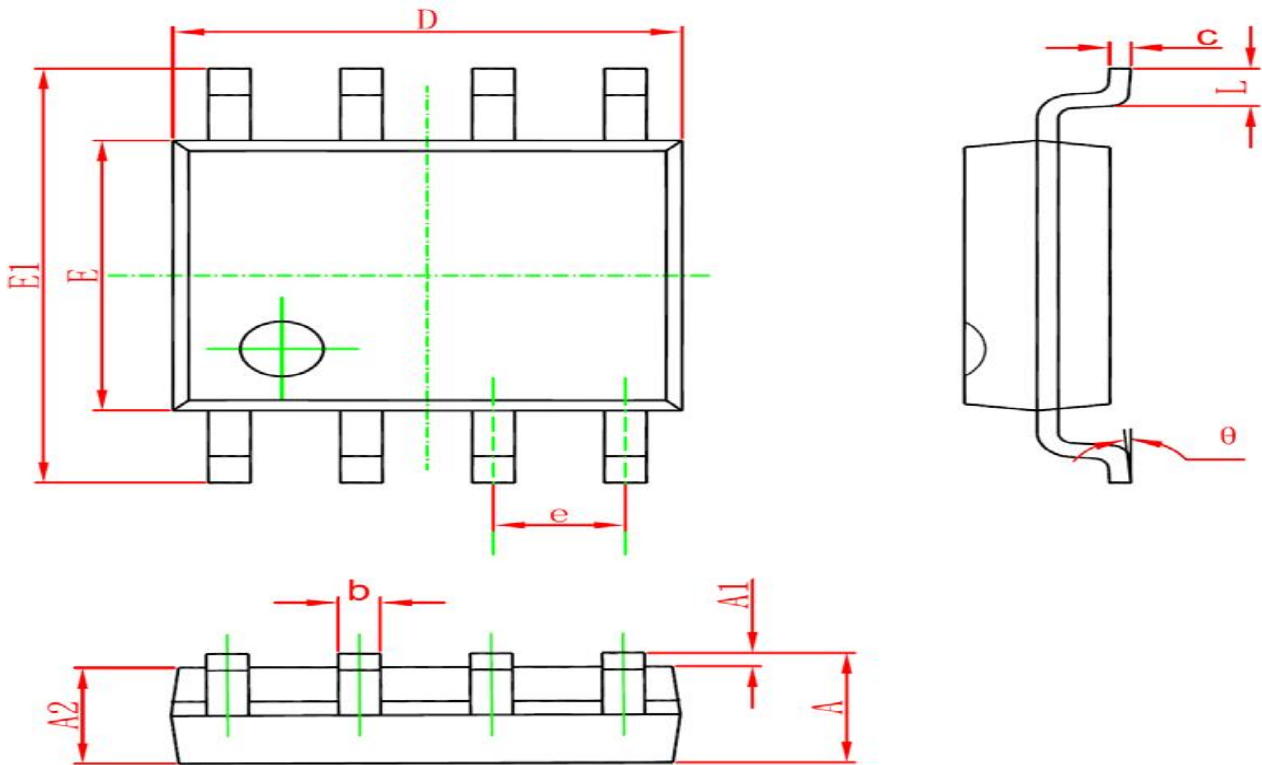

Symbol	Dimensions In Millimeters		Dimensions In Inches	
	Min	Max	Min	Max
A	1.350	1.750	0.053	0.069
A1	0.100	0.250	0.004	0.010
A2	1.350	1.550	0.053	0.061
b	0.330	0.510	0.013	0.020
c	0.170	0.250	0.006	0.010
D	4.700	5.100	0.185	0.200
E	3.800	4.000	0.150	0.157
E1	5.800	6.200	0.228	0.244
e	1.270		0.050	
L	0.400	1.270	0.016	0.050
θ	0°	8°	0°	8°

WS2814C

Single Line/256 Grayscale/Four Channel/
Constant Current/LED Driving IC

- **FSOP8 Package**

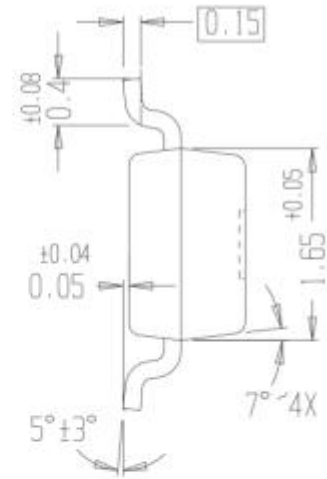
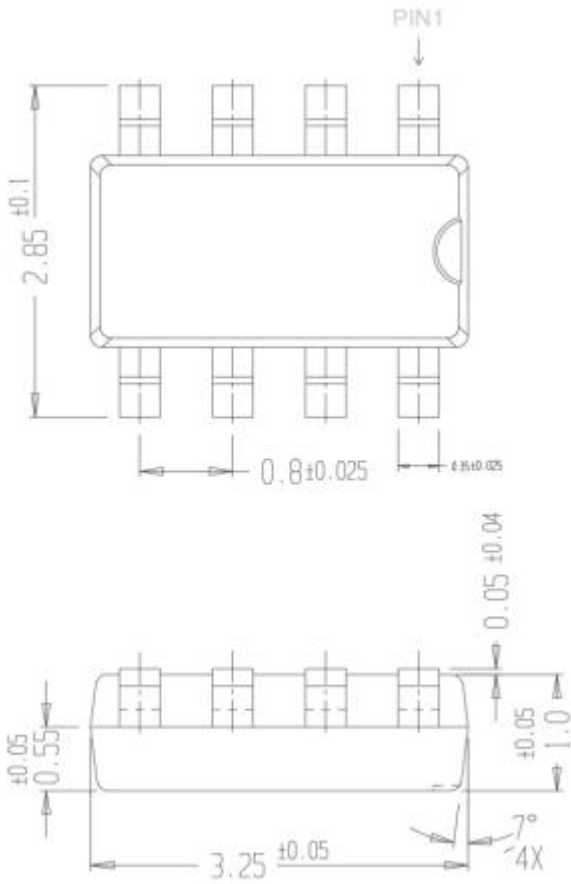

WS2814C

Single Line/256 Grayscale/Four Channel/
Constant Current/LED Driving IC

Record of File Alteration

Version	Condition	Outline of Alteration	Date	Modifier	Approver
V1.0	N	Establishment	20190410	Dong Le	Shen Jinguo
V1.1	M	Revision of detailed parameters	20210118	Dong Le	Shen Jinguo
V1.2	M	Revision of typically applied circuit	20211125	Xie Yanfan	Yu Xinghui
V1.3	M	Addition of item ESD	20220712	Hu Jin	Yu Xinghui
V1.4	A	Addition of FSOP8 package	2023/3/28	Hu Jin	Yu Xinghui
V1.5	M	To avoid misleading, make FSOP8 package an independent part	20230422	Hu Jin	Yu Xinghui
V2.0	M	<ul style="list-style-type: none">The conduction time between RGBW ports is staggered by 30us, and the port refresh frequency is increased to 4kHz, which can effectively reduce power ripple.The IC printing is changed from WS2814A to WS2814C.	20231107	Hu Jin	Yin Huaping

PS. The initial version is V1.0; the number of version plus 0.1 after every modification; Conditions including: N--newly built, A--addition, M--modification, D--delete.