WS2814

Single line 256 Gray level 4-channel Dual-Input Constant current LED driver IC

Feature

- R, G, B, W output port withstand voltage 20V, DIN1, DIN2 port withstand voltage 9V.
- Built-in voltage-regulator tube, only a resistance needed to add to IC VDD feet when under 24V power supply.
- 256 Gray-scale adjustable and scan frequency is more than **2KHz**.
- Built in signal reshaping circuit, to ensure waveform distortion do not accumulate after wave reshaping to the next driver.
- Built-in electrify reset circuit and power-down reset circuit.
- Cascading port transmission signal by single line.
- Any two point the distance less than two meters' transmission signal without any increase circuit.
- When the refresh rate is 30fps, the cascade number is at least 1024 pixels.
- Send data at speed of 800Kbps.

Applications

- LED full color decorative lighting, such as LED string, LED strip, LED module etc.
- Indoor/outdoor LED video or irregular screen.

General description

WS2814 is 4 output channels special for LED driver circuit. Its internal includes intelligent digital port data latch and signal reshaping amplification drive circuit. Also include a precision internal oscillator and a 20V voltage programmable constant current output drive. In the purpose of reduce power supply ripple, the 3 output channels designed to delay turn-on function.

IC use single NZR communication mode. After the chip power-on reset, the DIN port receive data from controller, the first IC collect initial 32bit data then sent to the internal data latch, the other data which reshaping by the internal signal reshaping amplification circuit sent to the next cascade IC through the DO port. After transmission for each chip, the signal to reduce 32bit. IC adopt auto reshaping transmit technology, making the chip cascade number is not limited the signal transmission, only depend on the speed of signal transmission.

The data latch of IC depend on the received 32bit data produce different duty ratio signal at OUTF,G,B,W ports. All chip synchronous send the received data to each segment when the DIN1 port input a reset signal. It will receive new data again After the reset signal finished. Before a new reset signal received, the control signal of OUTF,G,B,W ports unchanged. IC sent PWM data that received justly to OUTF,G,B,W ports, after receive a low voltage reset signal the time retain over **280μs**.

SOP12 package is available.

WS2814

Single line 256 Gray level 4-channel Dual-Input Constant current LED driver IC

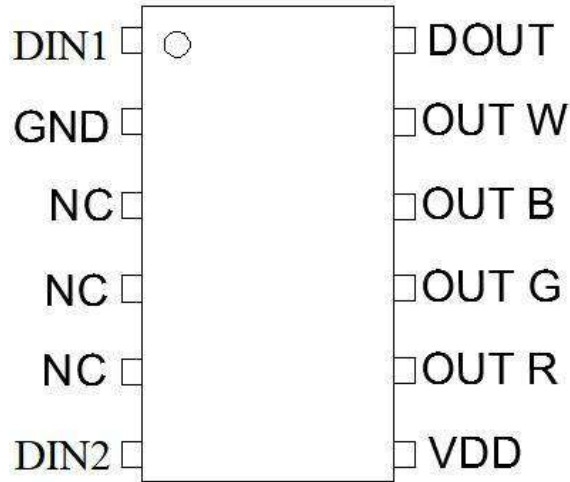

PIN function

NO.	Symbol	PIN	Function description
1	DIN1	Data1 Input	Display data 1 input
2	GND	Ground	Data & Power Grounding
3/4/5	NC	NC	-
6	DIN2	Auxiliary data input	Display data 2 input
7	VDD	Logic Power Supply	IC power supply
8	OUTR	LED Driver Output	Output of RED PWM control
9	OUTG	LED Driver Output	Output of GREEN PWM control
10	OUTB	LED Driver Output	Output of BLUE PWM control
11	OUTW	LED Driver Output	Output of WHITE PWM control
12	DOUT	Data Output	Display data cascade output

Absolute Maximum Ratings ($T_A=25^{\circ}\text{C}$, $V_{SS}=0\text{V}$, $V_{DD}=4.5\sim 5.5\text{V}$, unless otherwise noted.)

Parameter	Symbol	Ratings	Unit
Power Supply Voltage	V_{DD}	+3.7~+5.3	V
R/G/B/W Channel Output Port Withstand Voltage	V_{out}	20	V
Logical Input Voltage	V_I	0.7~ $V_{DD}+0.7$	V
Operation Temperature	T_{opt}	-25~+85	$^{\circ}\text{C}$
Storage Temperature Range	T_{stg}	-40~150	$^{\circ}\text{C}$

Note: If the voltage on the pins exceeds the maximum ratings may cause permanent damage to the device.

WS2814

Single line 256 Gray level 4-channel Dual-Input Constant current LED driver IC

Electrical Characteristics ($T_A=-20\sim+70^{\circ}\text{C}$, $V_{DD}=4.5\sim 5.5\text{V}$, $V_{SS}=0\text{V}$, unless otherwise specified)

Parameter	Symbol	Min	Tpy	Max	Unit	Conditions
R/G/B/W Low voltage output current	I_{OL}	15.5	16.5	17.5	mA	
Low voltage output current	I_{dout}	10	—	—	mA	$V_O=0.4\text{V}$, D_{OUT}
Input current	I_I	—	—	± 1	μA	$V_I=V_{DD}/V_{SS}$
Input voltage level	V_{IH}	$0.7V_{DD}$	—	$V_{DD}+0.7$	V	D_{IN}
	V_{IL}	-0.7	—	$0.3 V_{DD}$	V	D_{IN}
Hysteresis voltage	V_H	—	0.35	—	V	D_{IN}

Switching characteristics ($T_A=-20\sim+70^{\circ}\text{C}$, $V_{DD}=4.5\sim 5.5\text{V}$, $V_{SS}=0\text{V}$, unless otherwise specified)

Parameter	Symbol	Min	Tpy	Max	Unit	Condition
Transmission delay time	T_{PLZ}	—	—	300	ns	$CL=15\text{pF}$, $D_{IN}\rightarrow D_{OUT}$, $R_L=10\text{K}\Omega$
Fall time	T_{THZ}	—	—	120	μs	$CL=300\text{pF}$, $OUTR/OUTG/OUTB$
Data transmission rate	F_{MAX}	600	—	—	Kbps	Duty ratio 50%
Input capacity	C_i	—	—	15	pF	—

Data Transfer Time

T0H	0 code, high voltage time	220ns~380ns
T1H	1 code, high voltage time	580ns~1 μs
T0L	0 code, low voltage time	580ns~1 μs
T1L	1 code, low voltage time	580ns~1 μs
RES	Frame unit, low voltage time	>280 μs
Data Cycle	$T_{0H}+T_{0L}$, $T_{1H}+T_{1L}\geq 1.25\mu\text{s}$	

WS2814

Single line 256 Gray level 4-channel Dual-Input Constant current LED driver IC

Timing Waveform Diagram Sequence Chart

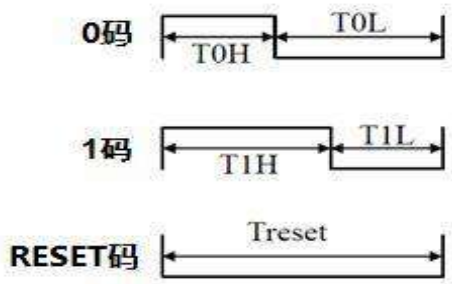

Cascade Method

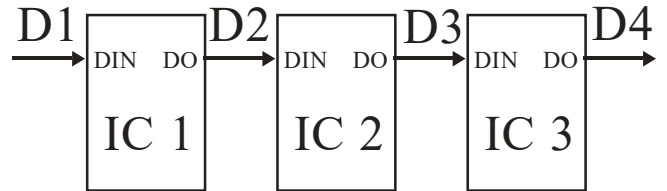

Data Transmission Method

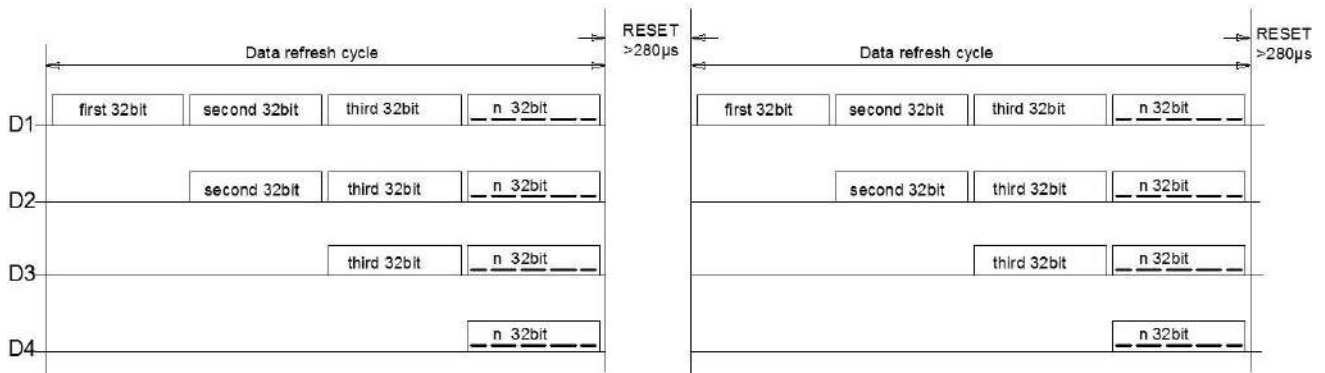

Note: The data of D1 is send by MCU,and D2, D3, D4 through IC internal reshaping amplification to transmit.

Composition of 32bit Data

R	R	R	R	R	R	R	R	G	G	G	G	G	G	G	G	B	B	B	B	B	B	B	B	W	W	W	W	W	W	W	W
7	6	5	4	3	2	1	0	7	6	5	4	3	2	1	0	7	6	5	4	3	2	1	0	7	6	5	4	3	2	1	0

Note: Data transmit in order of RGBW, high bit data at first.

WS2814

Single line 256 Gray level 4-channel Dual-Input Constant current LED driver IC

Typical Application Circuit

1. Supply voltage=12V(Each channel drives 3LEDs)

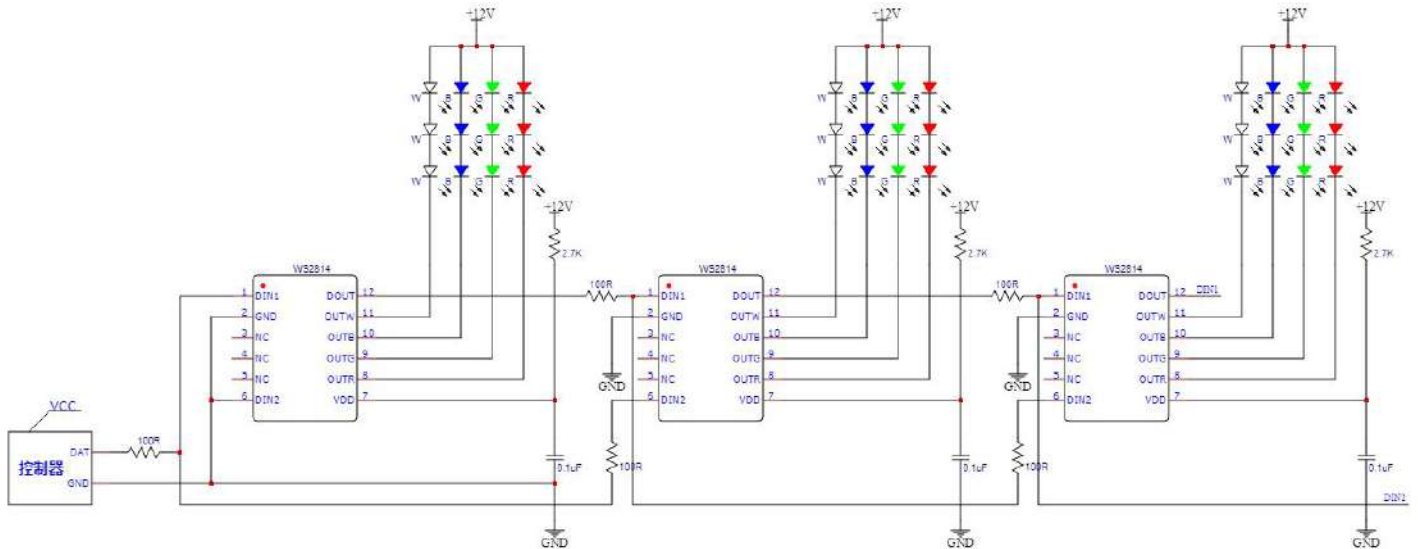

2. Supply voltage=24V(Each channel drives 6LEDs)

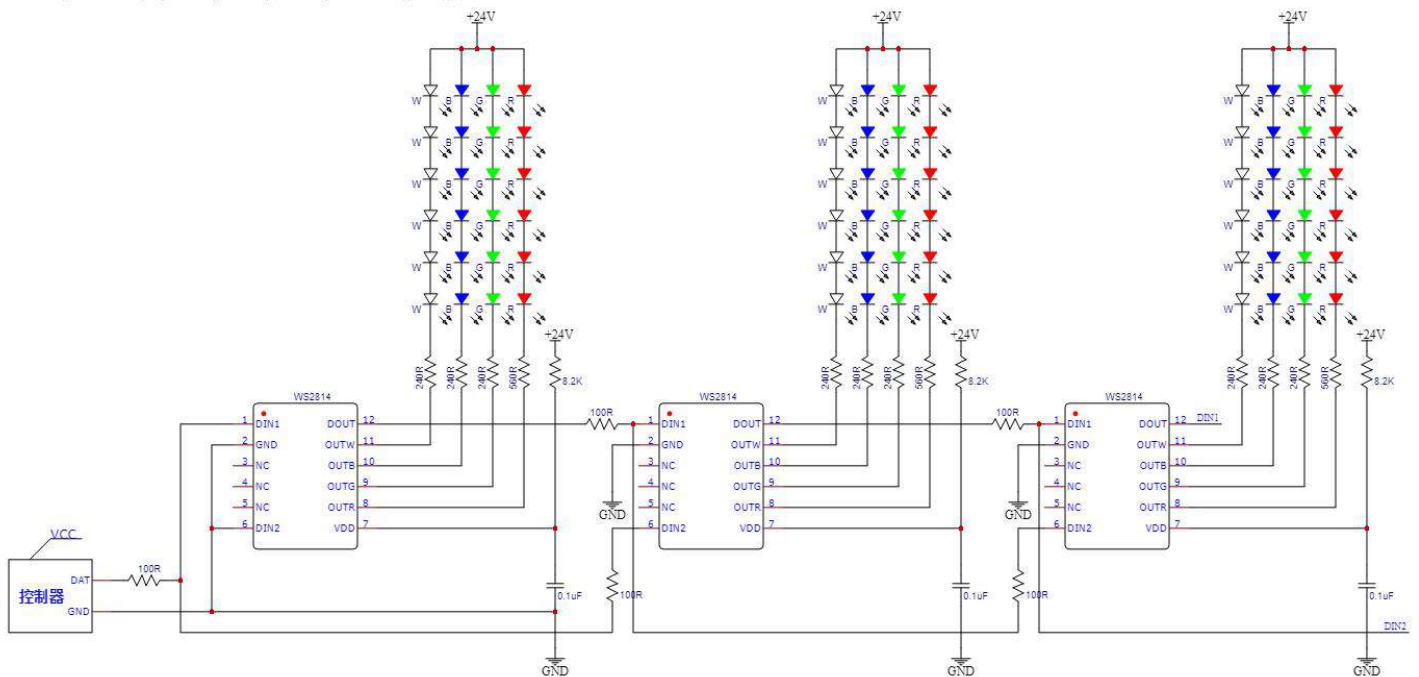

WS2814

Single line 256 Gray level 4-channel Dual-Input Constant current LED driver IC

Package information

- SOP12 package, 4000PCS per Reel

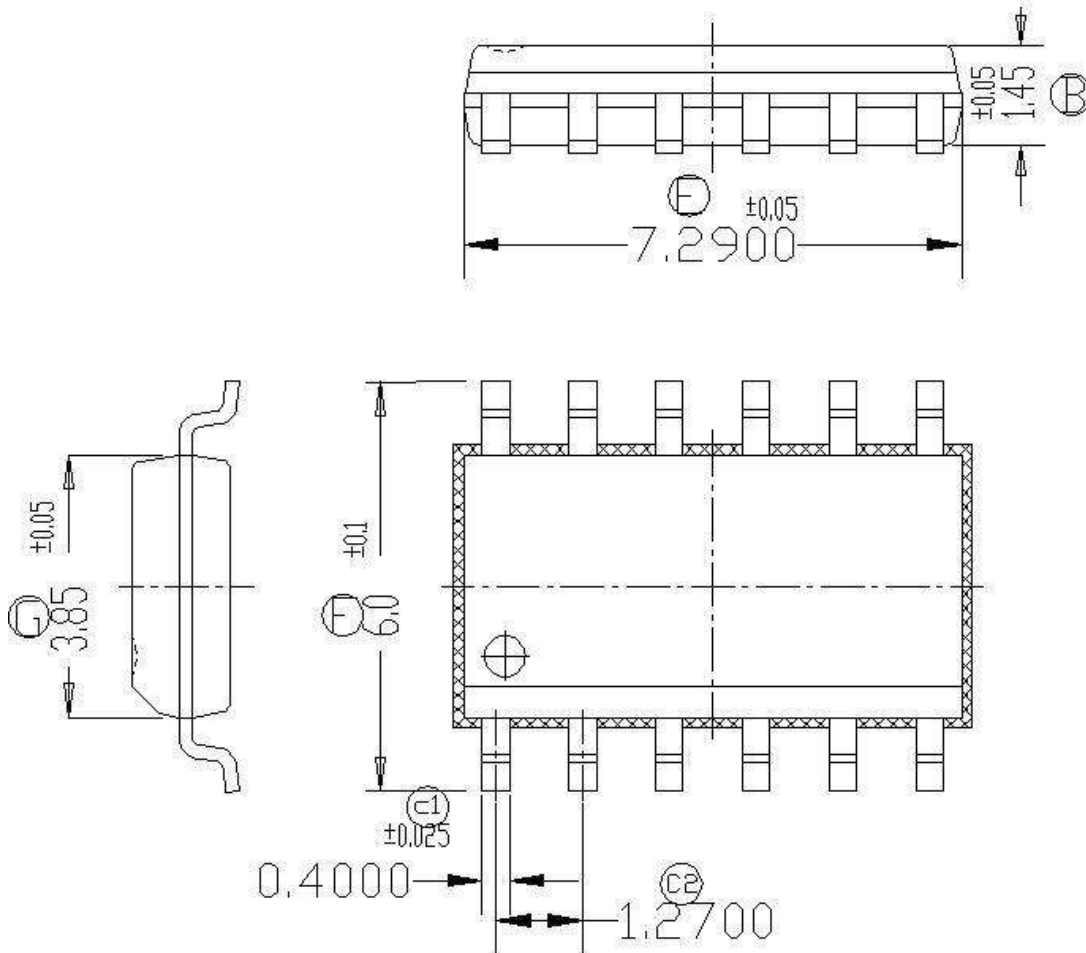

Symbol	Dimensions in Millimeters		
	Min.	NOM.	Max.
B	1.400	1.450	1.500
E	7.240	7.290	7.340
F	5.900	6.000	6.100
G	3.800	3.850	3.900
c1	0.375	0.400	0.425
c2	-	1.270	-

WS2814

Single line 256 Gray level 4-channel Dual-Input Constant current LED driver IC

Modify Records

Version №	Status Bar	Modify Content Summary	Date	Reviser	Approved
V1.0	N	New	20190410	Dong Le	Yin HuaPing
V1.1	M	Modify	20190522	Dong Le	Yin HuaPing
V1.2	M	Modify	20210401	Dong Le	Yin HuaPing
V1.3	M	Add typical application circuit	20211125	Xie YanFan	Yin HuaPing
V1.4	M	Detailed parameters updated	20220726	Hu Jin	Yin HuaPing

Remarks: Initial version: V1.0; Version number plus "0.1" after each revision;

Status bar: N--New, A--Add, M--Modify, D--Delete.