

---

# WS2801S

## 3-Channel Constant Current LED Driver With Programmable PWM Outputs

---

### Features

- Supports both constant voltage and constant current drive mode.
- Programmable constant LED drive current.
- Wide constant output current range 5~150mA.
- Build in PWM dimming scheme for each output channel, supports free-run, especially suitable for low cost controller application.
- PWM free-run capability(refresh rate(2.5KHz).
- Build in buffers to cascading data and clock to the next driver.
- Output polarity reverse function.
- Support hot swap.
- Maximum input clock frequency 25MHz.
- Power supply voltage 3.3~5.5V.

### Applications

- LED decorative lighting
- Indoor/Outdoor LED video or message display
- PWM signal generator
- LCD TV back lighting

### General Description

The WS2801 is a constant current LED driver. It is designed for indoor/ outdoor LED displays and decorative LED lighting system. It is suitable for LED cascading applications. The WS2801 owns 3 output channels, each channel can drive a constant current up to 30mA. WS2801 contains serial shift registers, data latches, output registers, band gap reference voltage generator, internal oscillator, and programmable constant output current drivers. The serial data is read into the shift registers at the rise edge of the external clock. The data and clock output buffers are designed for cascading another chip. The output polarity reverse function is designed for driving high power LED by adapting the application circuitry. The WS2801 adopts the reliable 2-wire scheme, which features low EMI transport, very strong anti-interference ability, and support hot-swap. The 2-wire control scheme can reduce the system cost; it is very suitable for low cost LED decorative LED lighting systems.

WS2801 is available in SOP-14 packages, the operating temperature is -40~85°C.

# WS2801S

## 3-Channel Constant Current LED Driver With Programmable PWM Outputs

### PIN Configurations

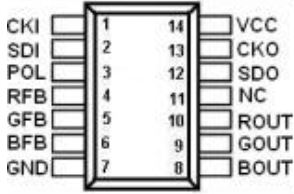
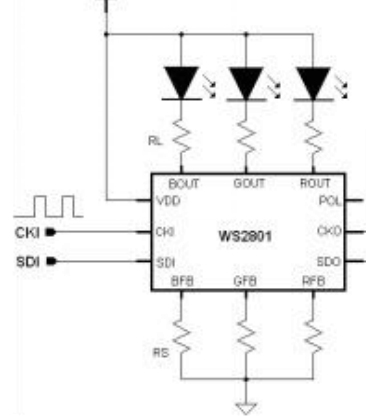

Fig1. SOP-14 package

### Typical Application Circuit



### Absolute Maximum Ratings

Parameter	Symbol	Ratings	Unit
Power Supply Voltage	VCC	-0.3 to 6V	V
Input Voltage	V <sub>IN</sub>	-0.3 to VCC+0.3V	V
Output Voltage	V <sub>OUT</sub>	-0.4 to 6V	V
Output Pin Voltage	V <sub>XOUT</sub>	-0.3 to 6V	V
Output Current Constant Current Drive Mode Constant Voltage Drive Mode	I <sub>OUTCC</sub> I <sub>OUTCV</sub>	0 to 50 0 to 100	mA
Output Current Deviation (Constant Current Driving Mode) Between output channels Between chips	D <sub>IOI</sub> D <sub>IOE</sub>	±1 ±3	%
Input Clock Frequency	F <sub>CLK</sub>	25	MHz
Maximum Power Dissipation	P <sub>D</sub>	600	mW
Operating Junction Temperature	T <sub>opr</sub>	-40 to + 150	°C
Storage Temperature Range	T <sub>stg</sub>	-55 to + 150	
Lead Temperature (Soldering, 10 seconds)	T <sub>solder</sub>	300	
ESD susceptibility		2000	V

Note: If the voltage on the pins exceeds the maximum ratings may cause permanent damage to the device.

# WS2801S

## 3-Channel Constant Current LED Driver With Programmable PWM Outputs

**Electrical Characteristics** (VCC=5V, TA= 25°C, unless otherwise specified.)

Parameter	Symbol	Conditions	Min	Typ	Max	Units
Power Supply Voltage Range	V <sub>CC</sub>		3.3	--	5. 5	V
Output Voltage	V <sub>OUT</sub>	I <sub>OUT</sub> =1uA	-0.3	--	5. 5	V
Output Current	I <sub>OUTH</sub>	Constant Current Output	5	--	30	mA
		Constant Voltage Output	--	--	50	mA
	I <sub>OUTL</sub>	Output Cut Off	--	0.1	1	uA
	I <sub>SOURCE</sub>	Other Output	--	1	--	mA
	I <sub>SINK</sub>	Other Output	--	-1	--	mA
Standby Supply Current	I <sub>STB</sub>	R/G/BOUT Floating	--	1	1. 5	mA
Minimum Constant Current Output Time	I <sub>OH</sub>	V <sub>IN</sub> =V <sub>IH</sub> or V <sub>IL</sub> , I <sub>OUT</sub> =20mA	--	14	--	uS
Input Current	I <sub>IN</sub>	PIN: CKI, SDI V <sub>IN</sub> =VDD or GND	--	--	±1	uA
		PIN: CKM, POL V <sub>IN</sub> =VDD or GND	--	±10	±20	uA
Input Voltage Level	V <sub>IH</sub>	TA=-40~125°C	0.8*V <sub>D</sub>	--	VDD	V
	V <sub>IL</sub>		GND	--	0.2*VDD	V
Constant Current Feed Back Voltage	V <sub>XFB</sub>	R <sub>R/G/BFB</sub> =20Ω	0.582	0.6	0.618	V
Output Saturation Voltage	V <sub>SAT</sub>	I <sub>OUT</sub> =20mA	--	0.4	0.6	V
Output Voltage Regulation	%dV <sub>OUT</sub>	V <sub>OUT</sub> =0.9~4, R <sub>RGBFB</sub> =30Ω	--	±0.1	--	%/V
Line Regulation	%dV <sub>CC</sub>	V <sub>CC</sub> =4~5.5V	--	±0.1	--	%/V
Pull High Resistance	R <sub>INHIGH</sub>	R <sub>POL</sub> , R <sub>CKM</sub>	--	30	--	KΩ

Note: If the voltage on the pins exceeds the maximum ratings may cause permanent damage to the device.

# WS2801S

## 3-Channel Constant Current LED Driver With Programmable PWM Outputs

### Switching Characteristics (VCC=5V, TA=25°C)

Parameter		Symbol	Conditions	Min	Typ	Max	Units
Propagation Delay ('L' to 'H')	CKI-to-CKO	$T_{pLH}$	$V_{IH}=V_{CC}$ $V_{IL}=GND$	--	8	--	ns
Propagation Delay ('L' to 'H')	CKI-to-CKO	$T_{pHL}$	$R_{XFBs}=30$ $R_L=180\Omega$ $C_L=30pF$	--	8.6	--	ns
Output Current Rise Time		$T_{or}$		--	50	--	ns
Maximum Turn ON and OFF time of Drive Current		$T_{of}$		--	50	--	ns
Output Current Propagation		① $T_{OP}$		--	--	3.3	mS

### Switching characteristics(VCC=3.3V, TA=25°C)

Parameter		Symbol	Conditions	Min	Typ	Max	Units
Propagation Delay ('L' to 'H')	CKI-to-CKO	$T_{pLH}$	$V_{IH}=V_{CC}$ $V_{IL}=GND$	--	9.0	--	ns
Propagation Delay ('L' to 'H')	CKI-to-CKO	$T_{pHL}$	$R_{XFBs}=30$ $R_L=180\Omega$ $C_L=30pF$	--	13	--	ns
Output Current Rise Time		$T_{or}$		--	50	--	ns
Maximum Turn ON and OFF time of Drive Current		$T_{of}$		--	50	--	ns
Output Current Propagation		① $T_{OP}$		--	--	3.3	mS

### Circuit for Switching Characteristics Test

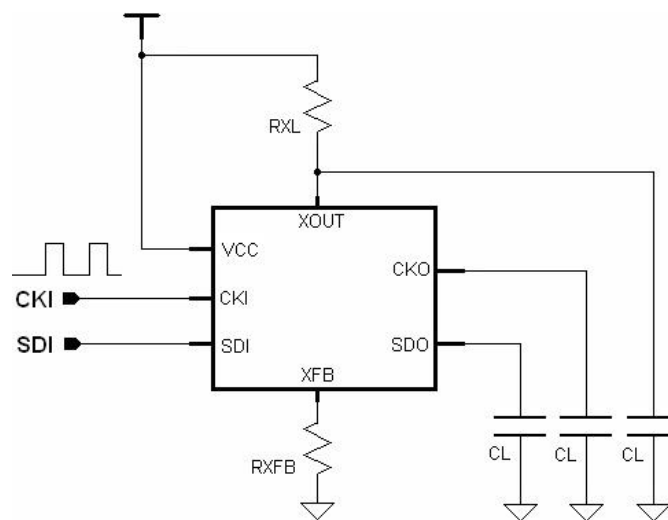

Fig2, Circuit for switching characteristics test

Note: ① Reload the gray scale data at each end of the PWM cycle.

# WS2801S

## 3-Channel Constant Current LED Driver With Programmable PWM Outputs

Typical Block Diagram

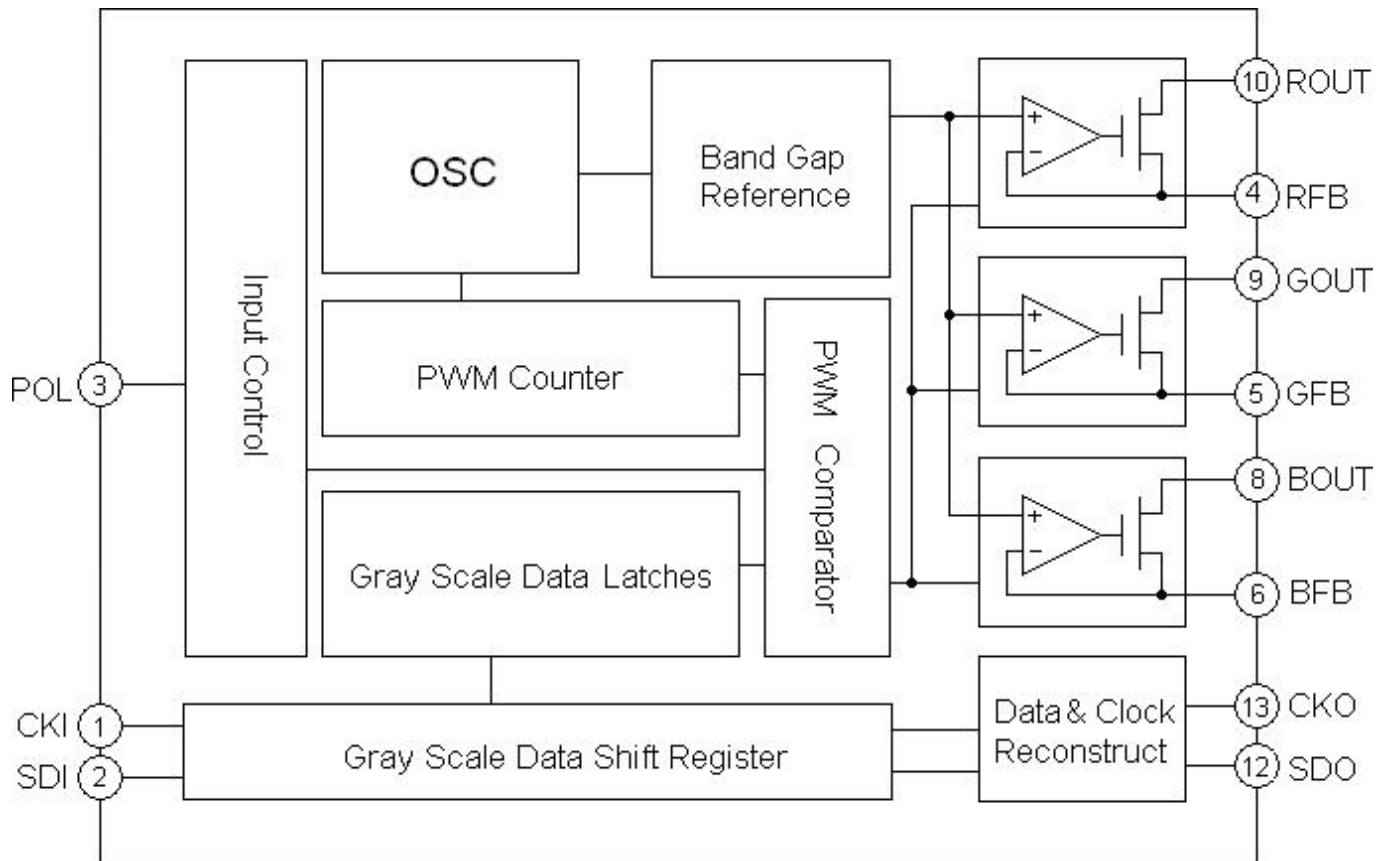

Fig3, Block Diagram of WS2801

---

# WS2801S

## 3-Channel Constant Current LED Driver With Programmable PWM Outputs

---

### PIN Description

PIN Port	PIN Name	PIN Description
1	CKI	Data clock input
2	SDI	Serial gray scale data input
3	POL	Output polarity control. <b>When POL is pulled to VCC</b> , the driver output will be reversed; when floating or pulled high, the output polarity will not be reversed.
4	RFB	The feed back of the R channel, a resistor connected to this pin can set the output constant current of the R channel
5	GFB	The feed back of the G channel, a resistor connected to this pin can set the output constant current of the G channel
6	BFB	The feed back of the B channel, a resistor connected to this pin can set the output constant current of the B channel
7	GND	Ground
8	BOUT	The output of the B channel
9	GOUT	The output of the G channel
10	ROUT	The output of the R channel
11	NC	None connection
12	SDO	The output of the serial gray scale data.
13	CKO	The output of the buffered clock
14	VCC	Power supply input, a capacitor can be connected from this pin to GND to enhance the noise immunity.

# WS2801S

## 3-Channel Constant Current LED Driver With Programmable PWM Outputs

### Application Information

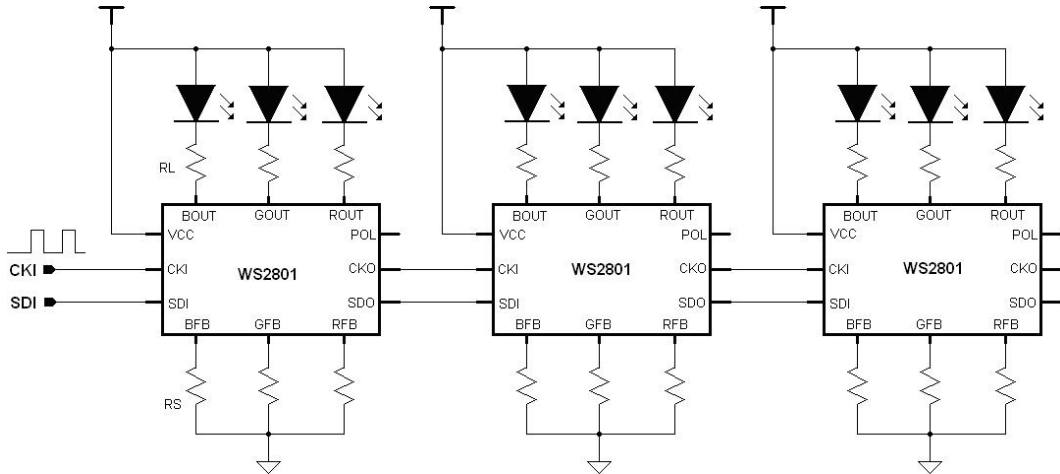
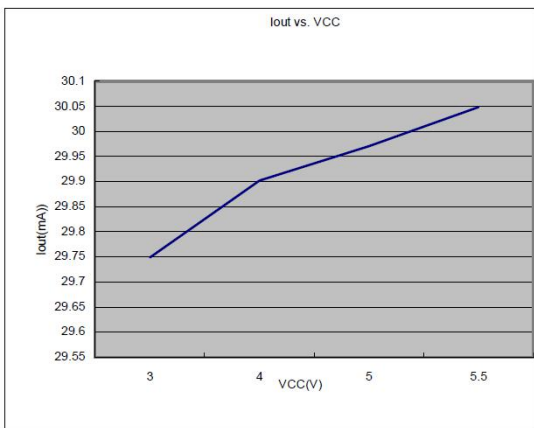
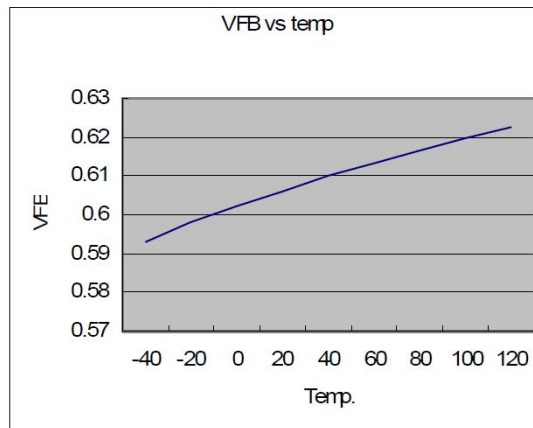

Fig4, The typical application circuit of WS2801

### Figures



Output current vs. Temp (RFB=20Ω)



Feed back voltage vs. temp.

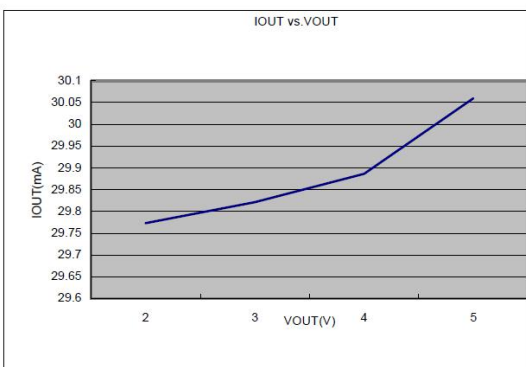

Output current vs. output voltage

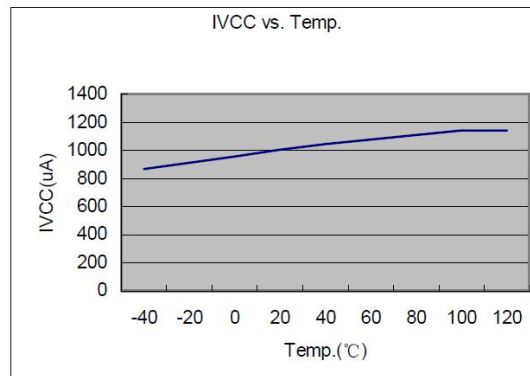

Ivcc vs. Temp.

# WS2801S

## 3-Channel Constant Current LED Driver With Programmable PWM Outputs

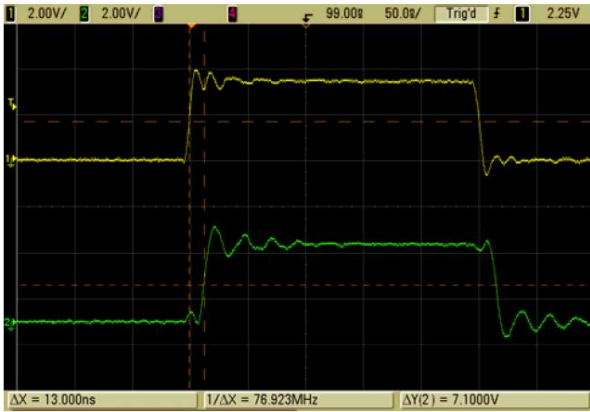

CKI to CKO delay time at rising edge(VCC=3.3V)

Channel1: CKI

Channel2: CKO

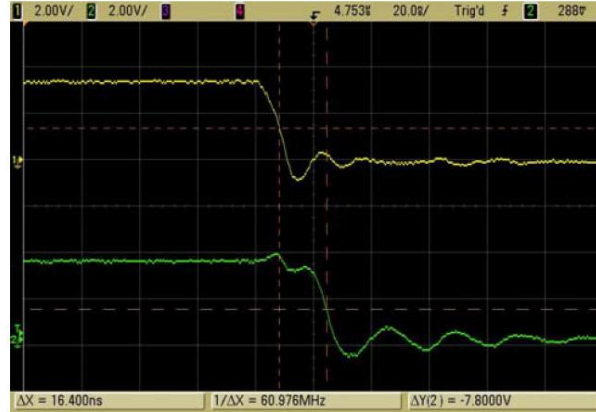

CKI to CKO delay time at falling edge(VCC=3.3V)

Channel1: CKI

Channel2: CKO



CKI to CKO delay time at rising edge(VCC=5V)

Channel1: CKI

Channel2: CKO

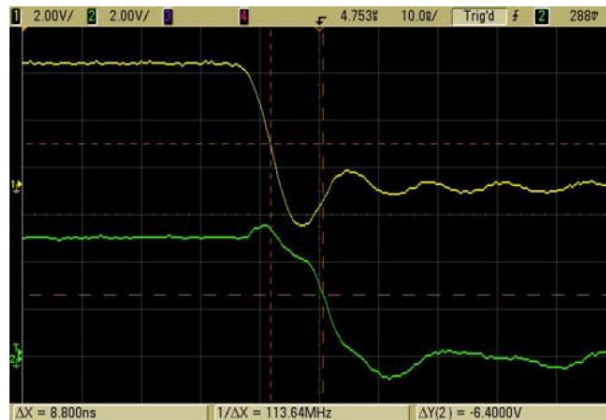

CKI to CKO delay time at falling edge(VCC=5V)

Channel1: CKI

Channel2: CKO

### Application note

#### Higher Voltage Applications:

The power supply range of WS2801 is from 3.3 to 6V, when the input power supply voltage is higher than 6V, a zener diode D0 can be used to clamp the voltage to generate the power supply of the chip, see Fig 5.



---

# WS2801S

## 3-Channel Constant Current LED Driver With Programmable PWM Outputs

---

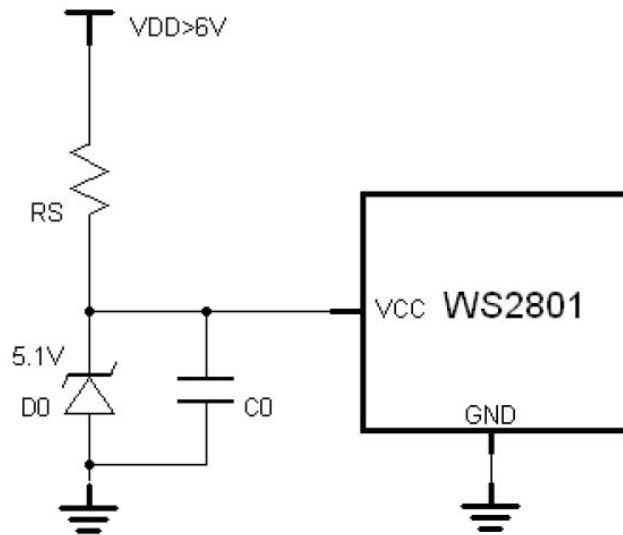

Fig5, the power supply for high voltage application  $V_{DD} > 6V$

As the WS2801S dissipates about 1.5mA current during normal operation, the current limit resistor  $R_S$  should be about 2 or more times of the current that dissipated in WS2801S, if the power supply  $V_{DD} = 12V$ , then  $R_S = 2K\Omega$  functions well. A capacitor  $C_0$  unnecessary to filter the noise on the generated power supply voltage for WS2801S, and  $C_0 = 1\mu F$  functions well for most of the applications.

### Constant Driving Current Mode

In WS2801S, a high performance OpAmp is applied to control the pass element  $M_0$  to generate a constant output current to drive the external LED strings. The output current of each channel can be set by adjusting the current feed back resistor connected at the current feed back pin(R/G/BFB), see Fig6.

---

# WS2801S

## 3-Channel Constant Current LED Driver With Programmable PWM Outputs

---

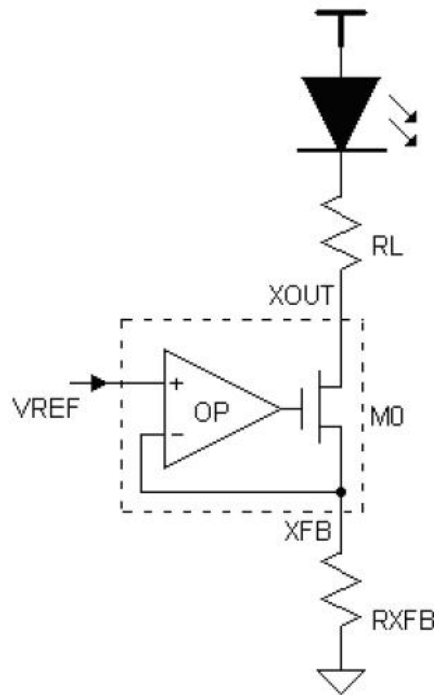

Fig6, The schematic of constant current drive

The output constant current can be set by the following equation:

$$I_{XOUT} = \frac{V_{REF}}{R_{XFB}} \text{-----(1)}$$

Where  $V_{REF}=0.6V$ , which is the current setting reference voltage,  $R_{XFB}$  is the current feed back resistor connected on R/G/BFB PIN, for example  $R_{XFB}=30\Omega$  to set  $I_{XOUT}=20mA$ , then  $R_{XFB}=30\Omega$ .

To guarantee the normal operation of the constant current drive, the voltage on R/G/BOUT should be set between 1 to 1.5 V, and then the drive can output a high precision current over whole operation range, meanwhile there would be not too much power dissipated on WS2801.

# WS2801S

## 3-Channel Constant Current LED Driver With Programmable PWM Outputs

### Constant Voltage Driving Mode

WS2801 is a versatile LED driver, it does not only provide user constant current driving mode, but also constant voltage driving mode, which is compatible with ZQL9712. The constant voltage driving mode (POL='HIGH' or floating) can drive the LEDs with current up to 50mA. Connecting R/G/BFB directly to ground, then WS2801 can operate at constant voltage driving mode. See Fig7.

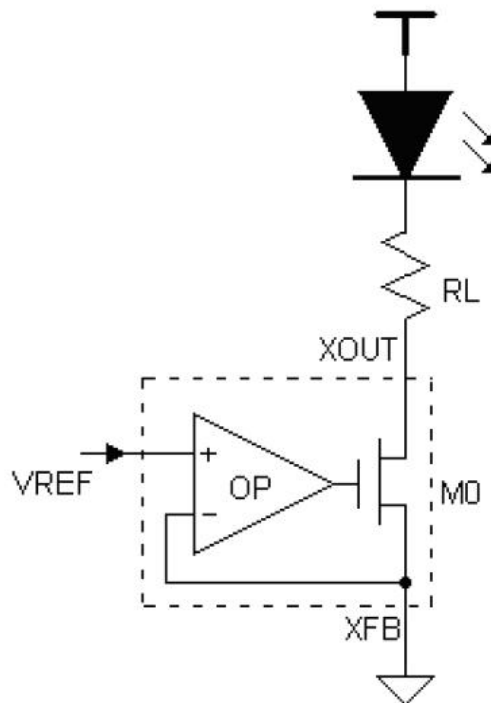

Fig7, The schematic of constant voltage driving mode

At constant voltage driving mode, the LED driving current can be set by adjusting RL; the RL can be derived by the following equation:

$$R_L = \frac{V_{DD} - V_{LED} - V_{OUT}}{I_{LED}} \quad \text{----- (2)}$$

Where RL is the current setting resistor, VDD is the LED power supply, VLED is the LED forward conducting voltage drop, VOUT is the saturation voltage of the output driver (about 0.2~0.4V), ILED is the LED operating current, usually  $I_{LED} \leq 20\text{mA}$ .

# WS2801S

## 3-Channel Constant Current LED Driver With Programmable PWM Outputs

### Constant Voltage Driving Mode with External Switches

WS2801 provides constant voltage driving mode with external switches to drive high brightness LED, and also realize the HB LED 256 gray scales control, **when POL is pull to VCC**, WS2801 can operate at this driving mode, see Fig8.

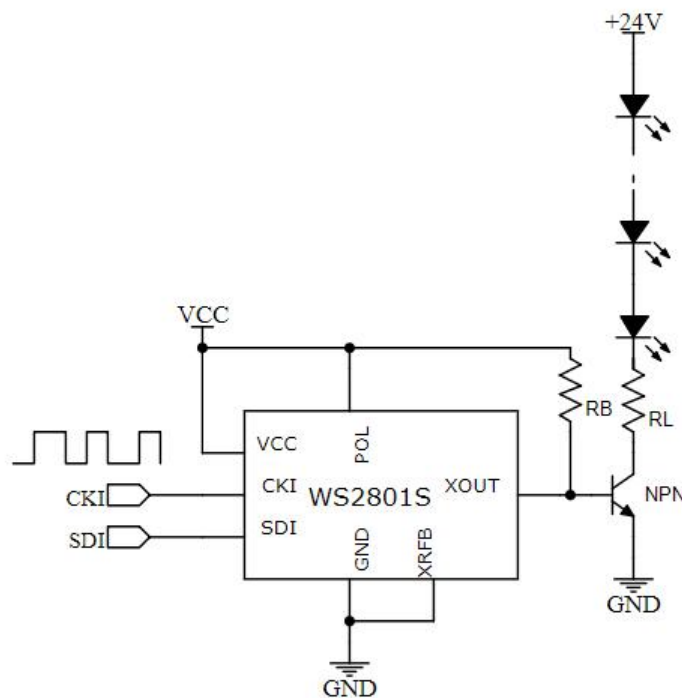

Fig8, Constant Voltage Driving with External Power Switches.

This driving mode is mainly used in high input voltage, high LED driving current ( $I_{LED} > 300\text{mA}$ ). Its operating principle is using the external power NPN switches to driving the LED lamps. The LED driving current can be adjusted by the external current limiting resistor  $R_L$ ,  $R_L$  can be derived by the following equation:

$$R_L = \frac{V_{DD} - V_{LED} - V_{CE}}{I_{LED}} \quad (2)$$

The external NPN transistor operates in saturation region,  $V_{CE}$  is the saturation voltage, and  $V_{CE} = 0.5 \sim 0.8\text{V}$ , the base resistor  $R_B = 2 \sim 5\text{k}$ .

# WS2801S

## 3-Channel Constant Current LED Driver With Programmable PWM Outputs

### Constant Current Driving Mode with External Switches

This driving mode makes WS2801 can drive the cascading LED lamps with extreme low cost, at this mode, **POL=VCC**, see Fig9.

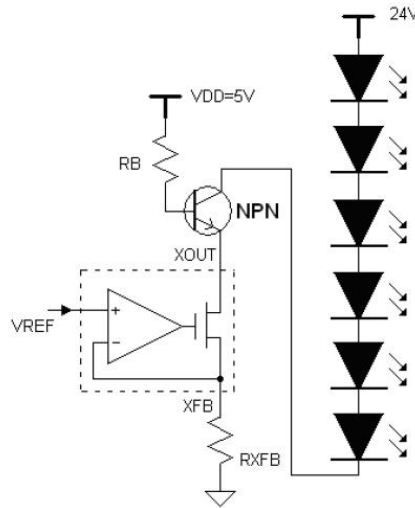

Fig9, Constant current drive with external switches

This mode can be used to drive the LED strings under high input voltage ( $V_{IN} > 6V$ ), the highest application voltage is determined by the external NPN power switch. The current flows through the collector of the NPN transistor:

$$I_{NPNC} = I_{XOUT} \frac{\beta}{\beta + 1} \text{-----} (4)$$

The current flow through the base is:

$$I_{NPNB} = I_{XOUT} \frac{1}{\beta + 1} \text{-----} (5)$$

During normal operation, to avoid too much power dissipating on WS2801, the voltage at R/G/BOUT should be set around 1.2 volts; the value of  $R_B$  can be derived by the following equation:

$$R_B = \frac{V_{DD} - V_{XOUT}}{I_{NPNB}} \text{-----} (6)$$

---

# WS2801S

## 3-Channel Constant Current LED Driver With Programmable PWM Outputs

---

### Gray Scale Data Word Format and Timing

CLK pin keeps low more than 500uS will make the WS2801 internal status register reset, and at this moment, the gray scale data in the data shift registers will be latched. Now WS2801 is ready for gray scale data transport. When the WS2801 receives total 24 clock rising edges, the WS2801 enters relay mode, which relays the input signal got from CKI and SDI with very low distortion (100pS typical) and very low delay time ( 8ns typical). The data format and the timing diagram can be seen in Fig 10.

The gray scale data frame is comprised of 3 gray data words, each data word is composed of 8 gray scale data bits, total 24 bits.

The 8bit gray data can easily realize the linear 256 LED gray levels control.

During data transfer, the first bit is the data frame signal, then is the MSB of the R<sub>OUT</sub> channel, the last one transferred into the data shift register is the LSB of the B<sub>OUT</sub> channel.

The duty cycle of the LED driving current can be calculated as:

$$D_{xOUT} = \frac{L[7]*2^7 + L[6]*2^6 + L[5]*2^5 + L[4]*2^4 + L[3]*2^3 + L[2]*2^2 + L[1]*2^1 + L[0]}{256} \text{----- (7)}$$

Where L[x]="0" or "1", which is R、 G、 B[x], x=0,1,2.....7 in the gray scale data. Gray scale data 0000 0000 is for the minimum 0 duty ratio, and 1111 1111 is for the maximum 255/256 duty ratio.

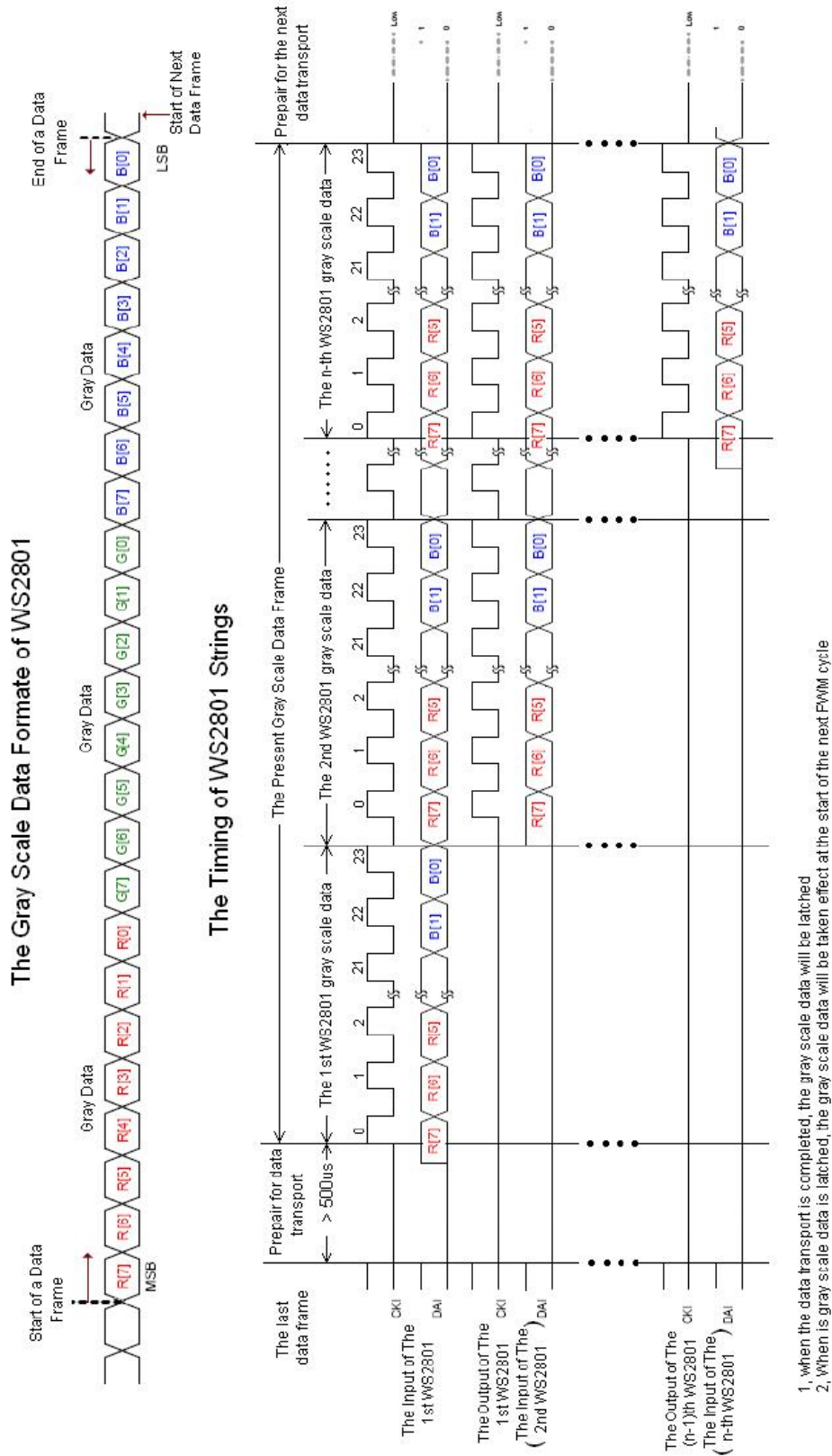

Fig 10, WS2801 data format and timing

# WS2801S

## 3-Channel Constant Current LED Driver With Programmable PWM Outputs

### The Connection and Driving of Cascading Operation

The transmit the data over long distance by cascading, the WS2801 integrates push-pull output stage with strong driving capability which enables the data and clock can be transmitted up to 6 meters at 2MHz clock frequency.

To prevent the reflection, it is necessary to connect a 50Ω resistor at the data input or output port for impedance match.

### Package Information

SOP-14 Package (Unit: mm)

