high gray scale display 12-channel LED display driver

UCS9812

GENERAL DESCRIPTION

The UCS9812 is a high gray scale display 12-channel LED display driver / controller with a built-in MCU digital interface, data latches and LED high voltage driving functions. It features superior performances and reliable functions. Under the control of the external MCU, it performs independent grayscale control through data-cascading transfer for driving large outdoor colour dot-matrix LED panels.

FEATURES

1. single line data transmission (return to zero code)
2. shaping transmit specific technology, Cascade number of lamps and lanterns is not restricted
3. cascading ability enhancement technology, Any 2 lanterns spacing can be up to 5 meters
4. Data transfer rate of 1100k/s, Images of not less than 600 points can be realized when the refresh rate of 30 frames per second, and not less than 300 points can be realized when the refresh rate of 60 frames per second
5. RGB output port PWM control can be achieved **65536** grey level adjustment, port scanning frequency of 5 KHz/s
6. Each channel contains 16 bit gray-scale data and 4 bit current data .Output port current can be set from 2.4mA to 20.4mA by change the 4 bit data
7. chip VDD built-in 5 v voltage regulator tube, output port Withstand Voltage is greater than 24 V
8. adopt the preset 17 mA/channel constant current mode. High precision of constant current , differences of current between Channel is less than $\pm 1.5\%$,the differences of current between Chip is less than $\pm 3\%$
9. SA-I Anti-interference patent technology for single line data transmission
10. There are 80 ns hysteresis between output port, Greatly reduce the switching noise
11. Industrial design, stable and reliable

Application:

LED display screen, LED striped screen Line light source
LED hurdle lamp LED decorate..

PIN CONFIGURATION

(SOP16, SSOP16)

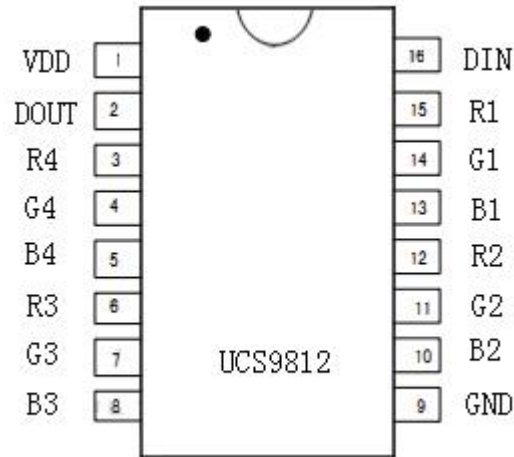

(QFN16)

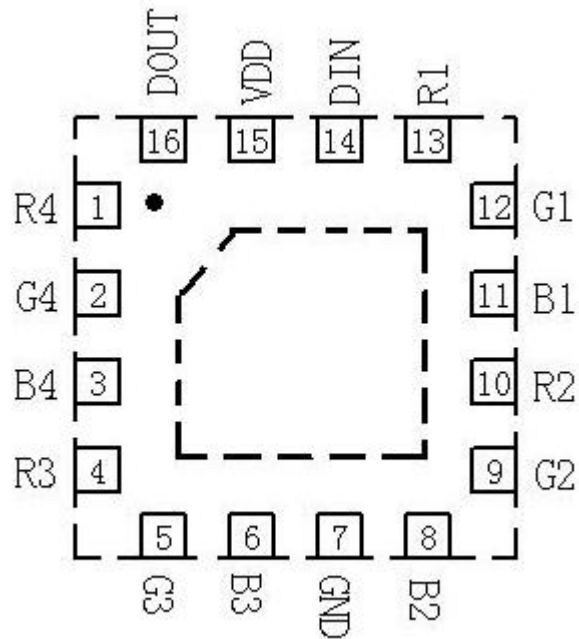

PIN DESCRIPTION

Number	Symbol	Name	Function Description
1	VDD		Logic power supply
2	DOUT	Data output	Display data cascaded output
3,6,12,15	OUTR	LED drive output	Red PWM control output
4,7,11,14	OUTG	LED drive output	Green PWM control output
5,8,10,13	OUTB	LED drive output	Blue PWM control output

9	GND	Ground	Ground
16	DIN	Data input	Display data cascaded input

ABSOLUTE MAXIMUM RATINGS ($T_A = 25\text{ }^\circ\text{C}$, $V_{SS} = 0\text{ V}$, unless otherwise specified)

Parameter	Symbol	Value	Unit
Logic supply voltage	V_{DD}	+7.0	V
Output port limitation voltage	V_{OUT}	28	V
Logic input voltage	V_I	-0.5 to $V_{DD} + 0.5$	V
Operating temperature	T_{OPT}	-40 to +85	$^\circ\text{C}$
Storage temperature	T_{STG}	-55 to +150	$^\circ\text{C}$
antistatic	ESD	8000	V
output rating	Pd	400	mW

RECOMMENDED OPERATING RANGES ($T_A = -20$ to $+70\text{ }^\circ\text{C}$, $V_{SS} = 0\text{ V}$, unless otherwise specified)

Parameter	Symbol	Min.	Typ.	Max	Unit
Logic supply voltage	V_{DD}	3	5.5	6	V
High level input voltage	V_{IH}	$0.7 V_{DD}$	-	V_{DD}	V
Low level input voltage	V_{IL}	0	-	$0.3 V_{DD}$	V
Output port rated voltage	V_{out}	24			V

ELECTRICAL CHARACTERISTICS ($T_A = -20$ to $+70\text{ }^\circ\text{C}$, $V_{DD} = 4.5$ to 5.5 V , $V_{SS} = 0\text{ V}$, unless otherwise specified)

Parameter	Symbol	Min.	Typ.	Max	Unit	Test conditions
Low level output current	I_{out}	2.4	18	20.4	mA	R, G, B
Low level output current	I_{do}	20	-	-	mA	$V_o = 0.4\text{ V}$, D_{out}
High level input voltage	V_{ih}	$0.6V_{DD}$	-		V	
Low level input voltage	V_{il}	-	-	$0.3V_{DD}$	V	
Voltage hysteresis	V_h	-	0.35	-	V	
current offset between channels	dI_{out}		± 1.5	± 3.0	%	$V_{ds} = 1\text{ V}$, $I_{out} = 18\text{ mA}$
current offset between IC	dI_{out}		± 3.0	± 5.0	%	$V_{ds} = 1\text{ V}$, $I_{out} = 18\text{ mA}$
current offset to V_{ds}	$\%dV_{ds}$		± 0.1	± 0.5	$\%/V$	$1\text{ V} < V_{ds} < 3\text{ V}$

current offset to Vdd	%dVds		±1.0	±2.0	%/V	4.5V<Vdd<5.5V
rated power	PD			250	mW	(Ta=25℃)
thermal resistance	Rth(j-a)		80	190	℃/W	

SWITCHING CHARACTERISTICS ($T_A = -20$ to $+70$ °C, $V_{DD} = 4.5$ to 5.5 V, $V_{SS} = 0$ V, unless otherwise specified)

Parameter	Symbol	Min.	Typ.	Max	Unit	Test conditions
Propagation delay time	t_{PLZ}	-	-	300	ns	$C_L = 15$ pF, DIN → DOUT, $R_L = 10$ kΩ
Fall time	t_{THZ}	-	-	120	μs	$C_L = 300$ pF, OUTR/OUTG/OUTB
Data transfer rate	F_{MAX}	1100	-	-	kbps	50% duty cycle
Input capacitance	C_I	-	-	15	pF	-

240-bit data format (Below is the first 60 bits data R1, G1, B1)

R19	R18	R17	R16	R15	R14	R13	R12	R11	R10	R9	R8	R7	R6	R5	R4	R3	R2	R1	R0
G19	G18	G17	G16	G15	G14	G13	G12	G11	G10	G9	G8	G7	G6	G5	G4	G3	G2	G1	G0
B19	B18	B17	B16	B15	B14	B13	B12	B11	B10	B9	B8	B7	B6	B5	B4	B3	B2	B1	B0

Note: The data is sent in the sequence of RGB, and the MSB is sent first.

UCS9812 The following is per channel 20 data structure

BIT19-BIT4 Gray level data, 16 bit, correspondence 65536 grey level

BIT3-BIT0 Constant current value data, 4 bit

[bit3~bit0] for setting OUTR OUTG, OUTB pin output constant current value, Numerical range from 2.4mA To 2.4mA, Each level of current difference is 1.2mA

OUTR/G/B	BIT3	BIT2	BIT1	BIT0	10进制	恒流值 (mA)
	0	0	0	0	0	2.4
	0	0	0	1	1	3.6
	0	0	1	0	2	4.8
	0	0	1	1	3	6
	0	1	0	0	4	7.2
	0	1	0	1	5	8.4
	0	1	1	0	6	9.6
	0	1	1	1	7	10.8

	1	0	0	0	8	12
	1	0	0	1	9	13.2
	1	0	1	0	10	14.4
	1	0	1	1	11	15.6
	1	1	0	0	12	16.8
	1	1	0	1	13	18
	1	1	1	0	14	19.2
	1	1	1	1	15	20.4

constant current characteristic

UCS9812 Constant current characteristic is excellent, between Channel , even between chip , the differences of current is tiny

(1): the differences of current between Channel is less than $\pm 1.5\%$ 。 the differences of current between Chip is less than $\pm 3\%$

(2): When the voltage of the load change, UCS9812 output current is not affected, as shown in the figure below

(3): Below UCS9812 output port of the current I_{out} and add on the port voltage V_{ds} curve relationship。 the smaller the I_{out} current, the smaller in the condition of constant current need of V_{ds} .

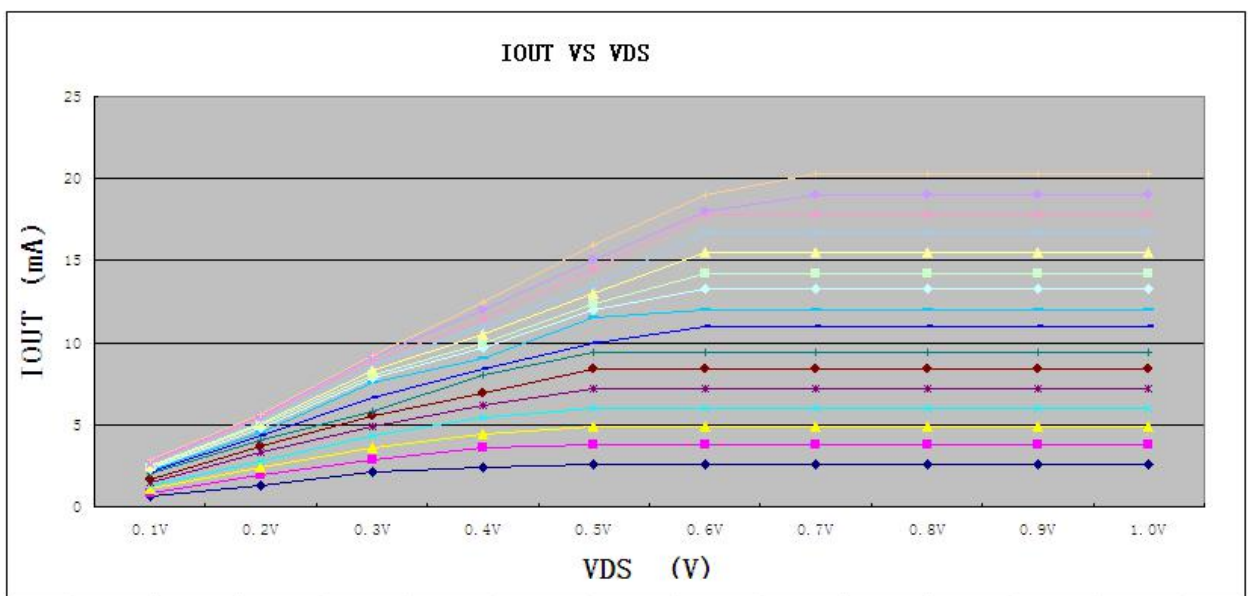

Typical Application circuit diagram

1. Power voltage is 5V

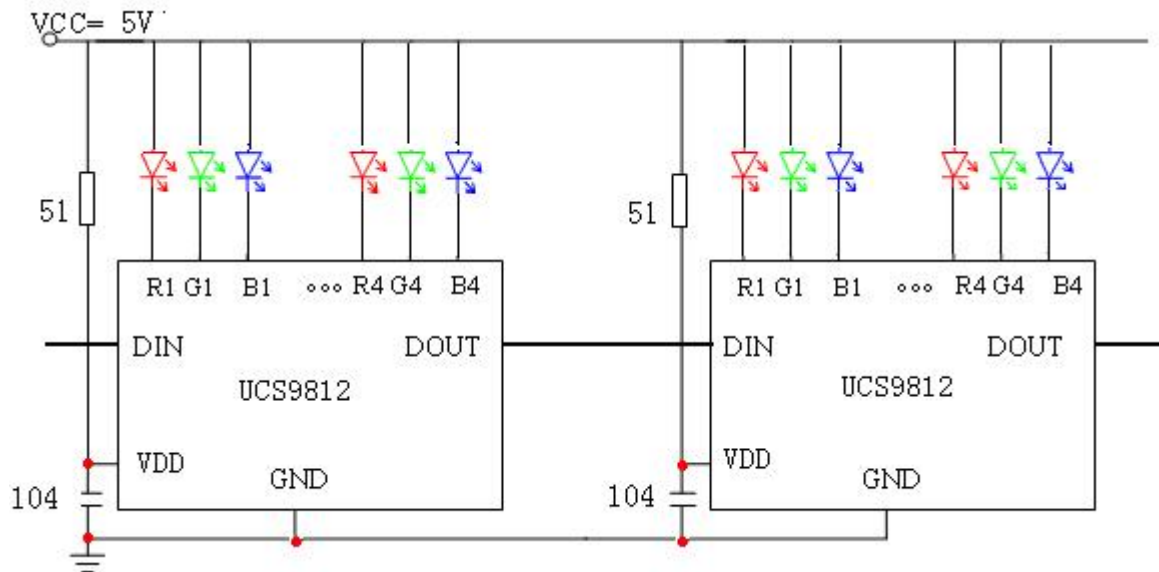

Using constant current mode can be voltage falling at the same time to achieve ideal effect of brightness and color temperature is kept constant.

2. Power voltage is 12V

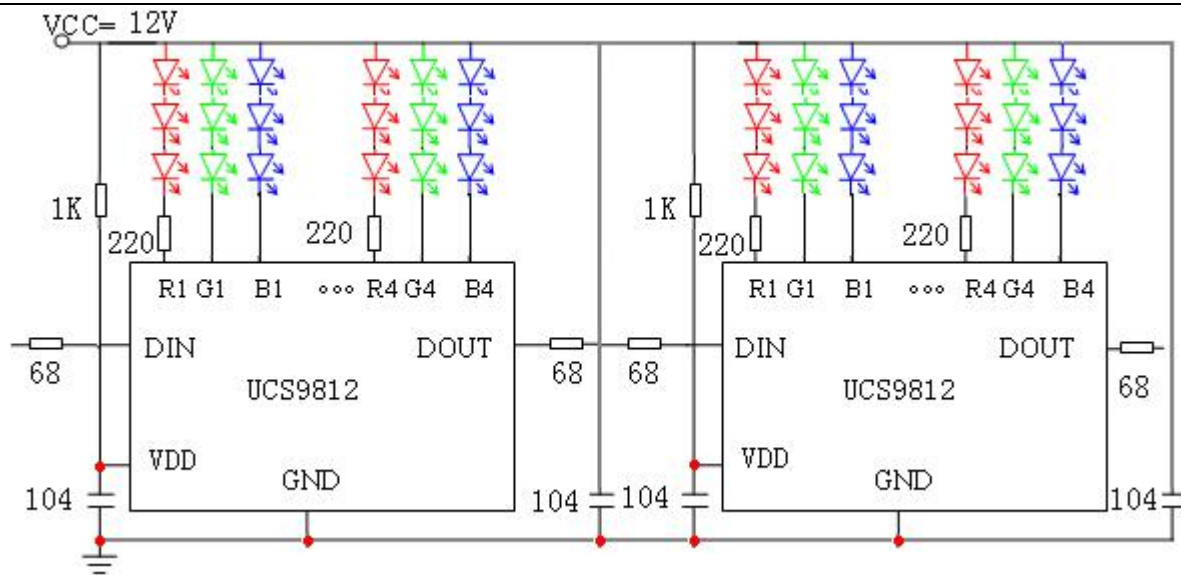

In order to prevent the damage of charged pull plug, when 12 v power supply, Din and Do all the string in a 68-80 ohm resistor for protection

In order to reduce the interference, between each lamps and lanterns of power supply and ground multiple a capacitance of 104 or 105

3. Power voltage is 24V

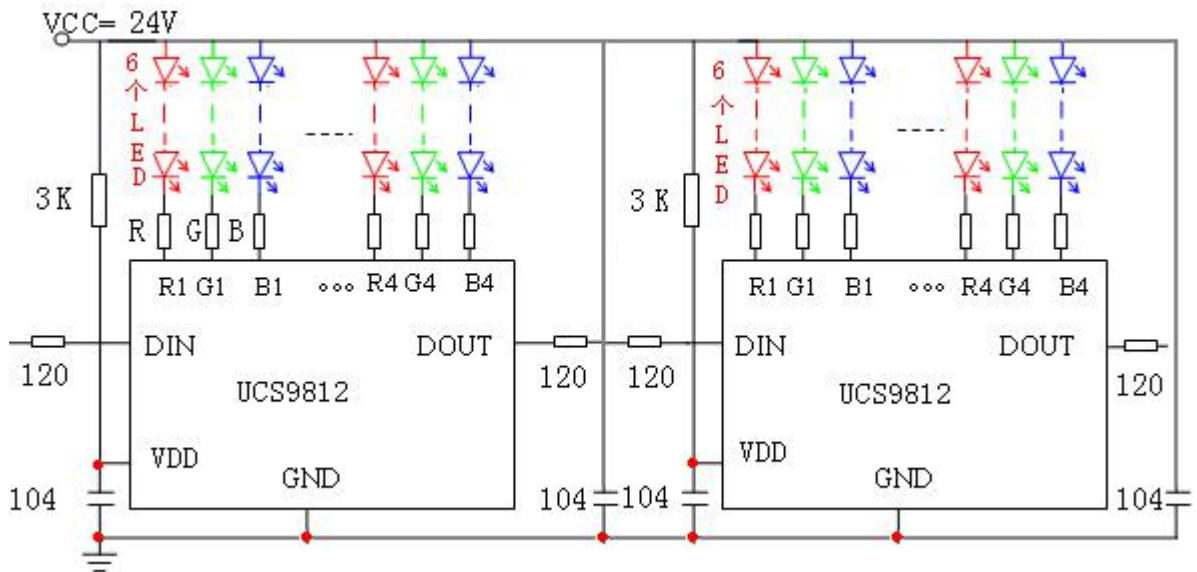

In order to prevent the damage of charged pull plug, when 24 v power supply, Din and Do all the string in a 120 ohm resistor for protection

In order to reduce the interference, between each lamps and lanterns of power supply and ground multiple a capacitance of 104 or 105

Vds Definition and values

Vds is the output voltage on the RGB pin. In order to avoid more than PD, Vds is no more than 4.5 v. The following formula is Vds:

$$V_{ds} = V_{CC} - I * R - N * V_{led}$$

Attention : I is Each string on the LED current , R is the resistance of LED series , N is the LED series connection number, Vled is the LED voltage

stabilizing voltage characteristic

UCS9812 built-in stabilizer, according to the power supply voltage (VCC) is different, must choose different resistance (R) for step-down voltage, Resistance to select in the table below for reference:

VCC (V)	R(ohm)
5	80
12	1K
15	1.5K
24	3K

package outline drawing AND DIMENSION

SOP16

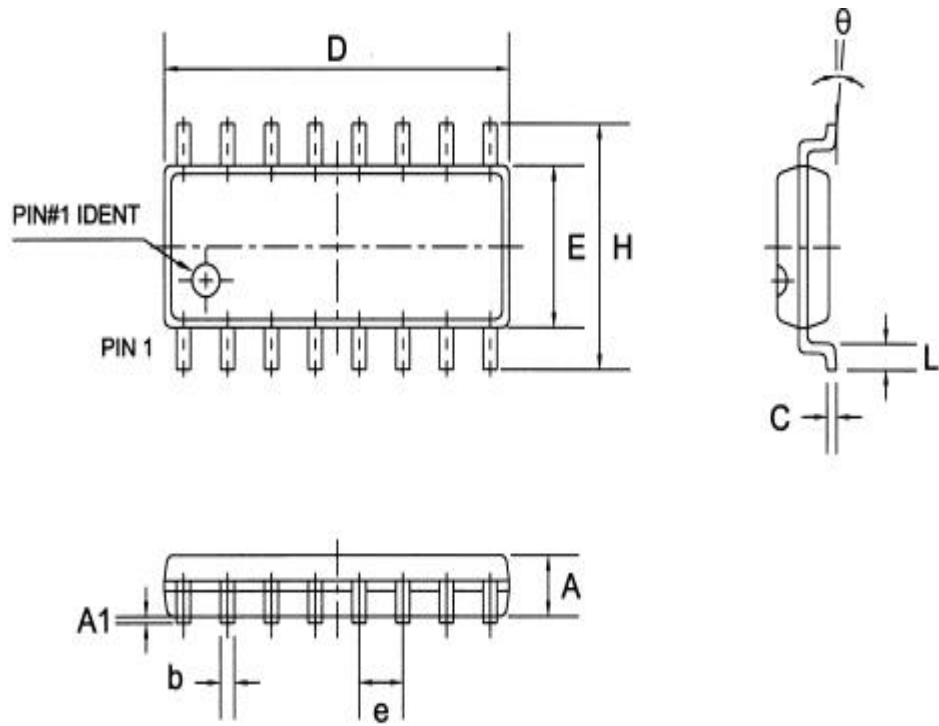

Symbol	Dimensions In Millimeters			Dimensions In Inches		
	Min	Nom	Max	Min	Nom	Max
A	1.30	1.50	1.70	0.051	0.059	0.067
A1	0.06	0.16	0.26	0.002	0.006	0.010
b	0.30	0.40	0.55	0.012	0.016	0.022
C	0.15	0.25	0.35	0.006	0.010	0.014
D	9.70	10.00	10.30	0.382	0.394	0.406
E	3.75	3.95	4.15	0.148	0.156	0.163
e	—	1.27	—	—	0.050	—
H	5.70	6.00	6.30	0.224	0.236	0.248
L	0.45	0.65	0.85	0.018	0.026	0.033
θ	0°	—	8°	0°	—	8°

SSOP16:

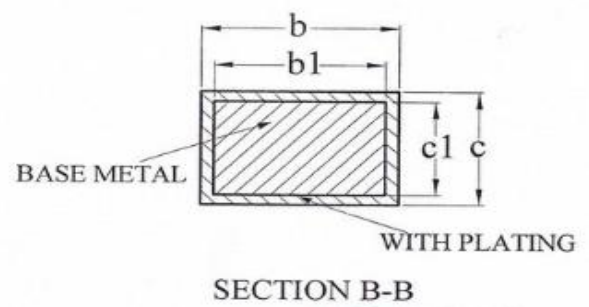
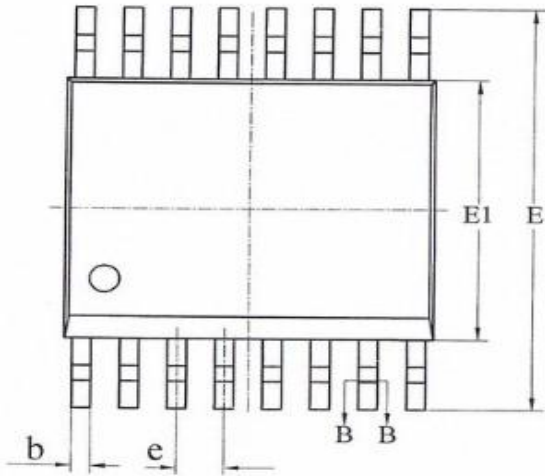
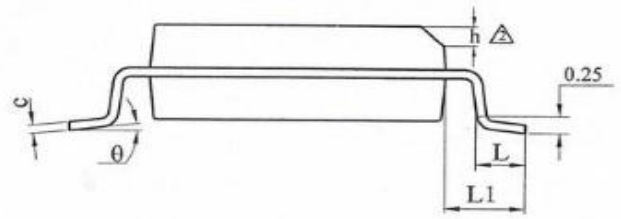
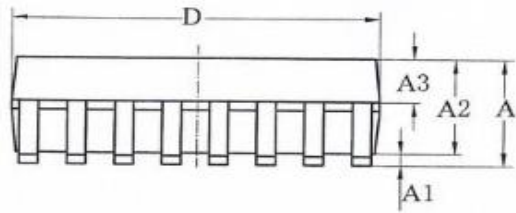

SECTION B-B

SYMBOL	MILLIMETER		
	MIN	NOM	MAX
A	—	—	1.75
A1	0.10	—	0.225
A2	1.30	1.40	1.50
A3	0.50	0.60	0.70
b	0.24	—	0.30
b1	0.23	0.254	0.28
c	0.20	—	0.25
c1	0.19	0.20	0.21
D	4.80	4.90	5.00
E	5.80	6.00	6.20
E1	3.80	—	4.00
e	0.635BSC		
h	0.25	—	0.50
L	0.50	0.65	0.80
L1	1.05BSC		
θ	0	—	8°
L/P载体尺寸 (mil)	93*92		100*160

QFN16: 0404*0.75-0.65

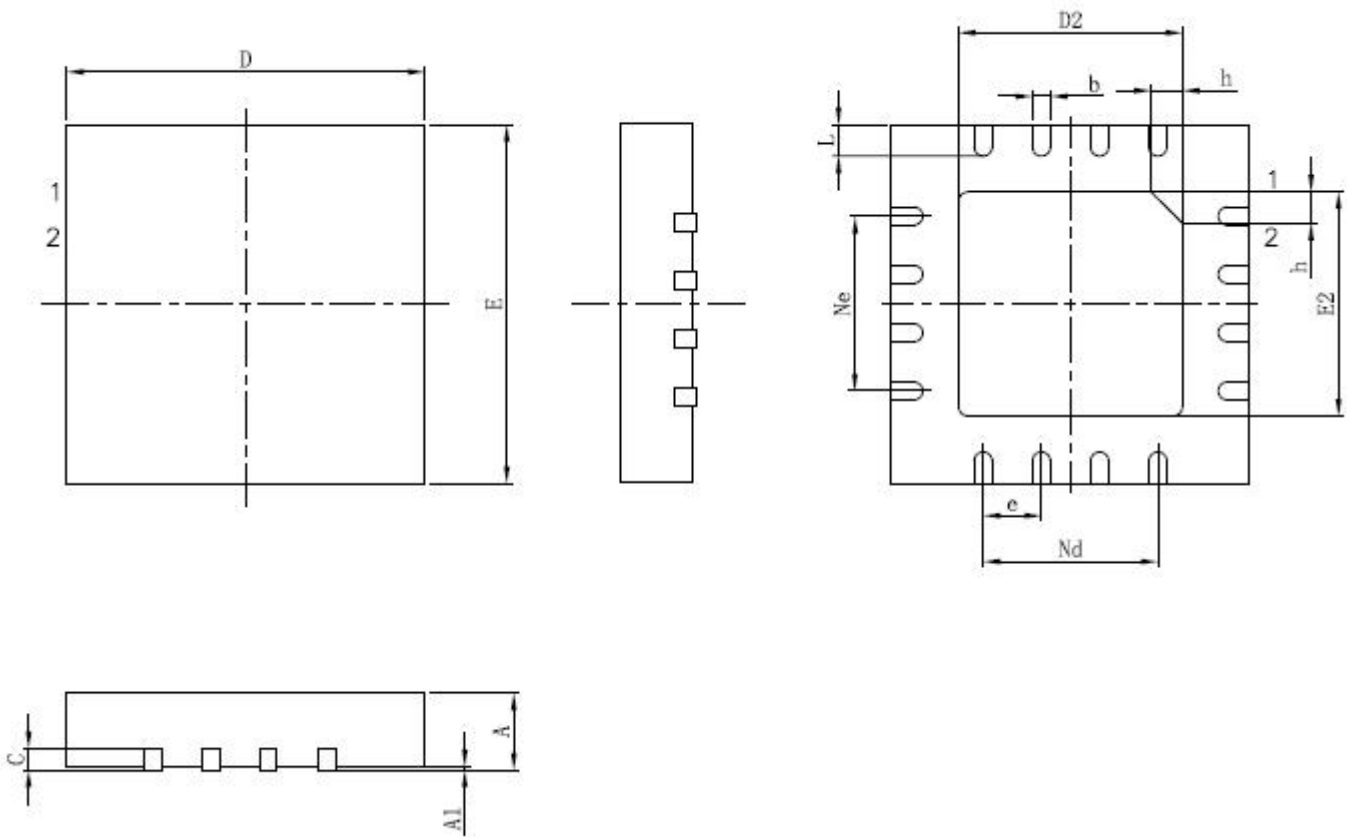

SYMBOL	MILLIMETER		
	MIN	NOM	MAX
A	0.70	0.75	0.80
A1	—	0.02	0.05
b	0.25	0.30	0.35
c	0.18	0.20	0.25
D	3.90	4.00	4.10
D2	2.10	2.20	2.30
e	0.650BSC		
Ne	1.95BSC		
Nd	1.95BSC		
E	3.90	4.00	4.10
E2	2.10	2.20	2.30
L	0.45	0.55	0.65
h	0.30	0.35	0.40
LP规格尺寸	98*98		

Version

versions	Issuing date	Revised profile
VER1.0	2012-2-15	The first issue