high gray scale display 3-channel LED constant current driver

UCS8903

GENERAL DESCRIPTION

The UCS8903 is a 3-channel LED display driver / controller with a built-in MCU digital interface, data latches and LED high voltage driving functions. It features superior performances and reliable functions. Under the control of the external MCU, it performs independent grayscale control through data-cascading transfer for driving large outdoor colour dot-matrix LED panels.

FEATURES

1. single line data transmission (return to zero code)
2. shaping transmit specific technology, Cascade number of lamps and lanterns is not restricted
3. cascading ability enhancement technology, Any 2 lanterns spacing can be up to 10 meters
4. Data transfer rate of 800 k/s, Images of not less than 512 points can be realized when the refresh rate of 30 frames per second,
5. RGB output port PWM control can be achieved 65536 grey level adjustment, port scanning frequency of 1 KHz/s
6. chip VDD built-in 5 v voltage regulator tube, output port Withstand Voltage is greater than 24 V
7. adopt the preset 17 mA/channel constant current mode. High precision of constant current , differences of current between Channel is less than $\pm 1.5\%$, the differences of current between Chip is less than $\pm 3\%$
8. when power up ,IC self-inspection then Light connection on the pin B lamp
9. SA-I Anti-interference patent technology for single line data transmission
10. Industrial design, stable and reliable

Application:

Point light source full color module full color light bar LED decorate..

PIN CONFIGURATION

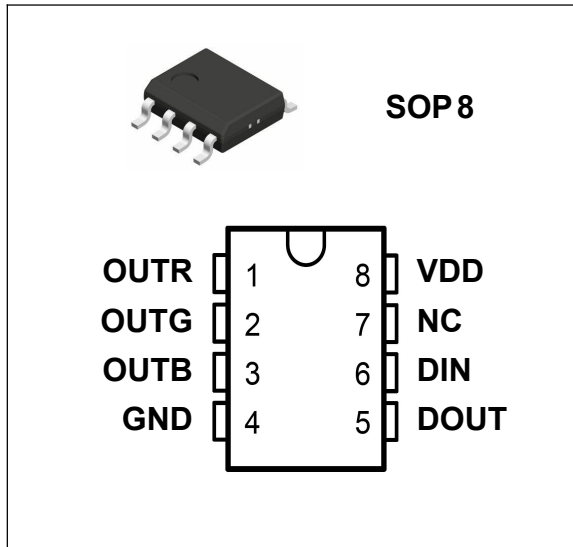

PIN DESCRIPTION

Number	Symbol	Name	Function Description
1	OUTR	LED drive output	Red PWM control output
2	OUTG	LED drive output	Green PWM control output
3	OUTB	LED drive output	Blue PWM control output
4	GND	Ground	Ground
5	DOUT	Data output	Display data cascaded output
6	DIN	Data input	Display data cascaded input
7	NC		
8	VDD		Logic power supply

ABSOLUTE MAXIMUM RATINGS ($T_A = 25\text{ }^\circ\text{C}$, $V_{SS} = 0\text{ V}$, unless otherwise specified)

Parameter	Symbol	Value	Unit
Logic supply voltage	V_{DD}	+7.0	V
Output port limitation voltage	V_{OUT}	28	V
Logic input voltage	V_I	-0.5 to $V_{DD} + 0.5$	V
Operating temperature	T_{OPT}	-40 to +85	$^\circ\text{C}$
Storage temperature	T_{STG}	-55 to +150	$^\circ\text{C}$
antistatic	ESD	6000	V
output rating	Pd	400	mW

RECOMMENDED OPERATING RANGES ($T_A = -20$ to $+70\text{ }^\circ\text{C}$, $V_{SS} = 0\text{ V}$, unless otherwise specified)

Parameter	Symbol	Min.	Typ.	Max	Unit
Logic supply voltage	V_{DD}	-	5.5	-	V
High level input voltage	V_{IH}	$0.7 V_{DD}$	-	V_{DD}	V
Low level input voltage	V_{IL}	0	-	$0.3 V_{DD}$	V
Output port rated voltage	Vout	24			V

ELECTRICAL CHARACTERISTICS ($T_A = -20$ to $+70\text{ }^\circ\text{C}$, $V_{DD} = 4.5$ to 5.5 V , $V_{SS} = 0\text{ V}$, unless otherwise specified)

Parameter	Symbol	Min.	Typ.	Max	Unit	Test conditions
Low level output current	Iout	16.5	17	17.5	mA	R, G, B
Low level output current	I _{do}	10	-	-	mA	$V_o = 0.4\text{ V}$, Dout
High level input voltage	V _{ih}	$0.6V_{DD}$	-		V	
Low level input voltage	V _{il}	-	-	$0.3V_{DD}$	V	
Voltage hysteresis	V _h	-	0.35	-	V	
quiescent current	I _{DDdyn}			1	mA	无负载
rated power	PD			250	mW	($T_a = 25\text{ }^\circ\text{C}$)
thermal resistance	R _{th(j-a)}		80	190	$^\circ\text{C/W}$	

SWITCHING CHARACTERISTICS ($T_A = -20$ to $+70$ °C, $V_{DD} = 4.5$ to 5.5 V, $V_{SS} = 0$ V, unless otherwise specified)

Parameter	Symbol	Min.	Typ.	Max	Unit	Test conditions
Propagation delay time	t_{PLZ}	-	-	300	ns	$C_L = 15$ pF, DIN → DOOUT, $R_L = 10$ kΩ
Fall time	t_{THZ}	-	-	120	μs	$C_L = 300$ pF, OUTR/OUTG/OUTB
Data transfer rate	F_{MAX}	800	-	-	kbps	50 % duty cycle
Input capacitance	C_I	-	-	15	pF	-

48-bit data format

R15	R14	R13	R12	R11	R10	R9	R8	R7	R6	R5	R4	R3	R2	R1	R0
G15	G14	G13	G12	G11	G10	G9	G8	G7	G6	G5	G4	G3	G2	G1	G0
B15	B14	B13	B12	B11	B10	B9	B8	B7	B6	B5	B4	B3	B2	B1	B0

Note: The data is sent in the sequence of RGB, and the MSB is sent first.

constant current characteristic

UCS8903 Constant current characteristic is excellent, between Channel, even between chip, the differences of current is tiny

(1): the differences of current between Channel is less than $\pm 1.5\%$. the differences of current between Chip is less than $\pm 3\%$

(2): When the voltage of the load change, UCS8903 output current is not affected, as shown in the figure below

(3): Below UCS8903 output port of the current I_{out} and add on the port voltage V_{ds} curve relationship. the smaller the I_{out} current, the smaller in the condition of constant current need of V_{ds} .

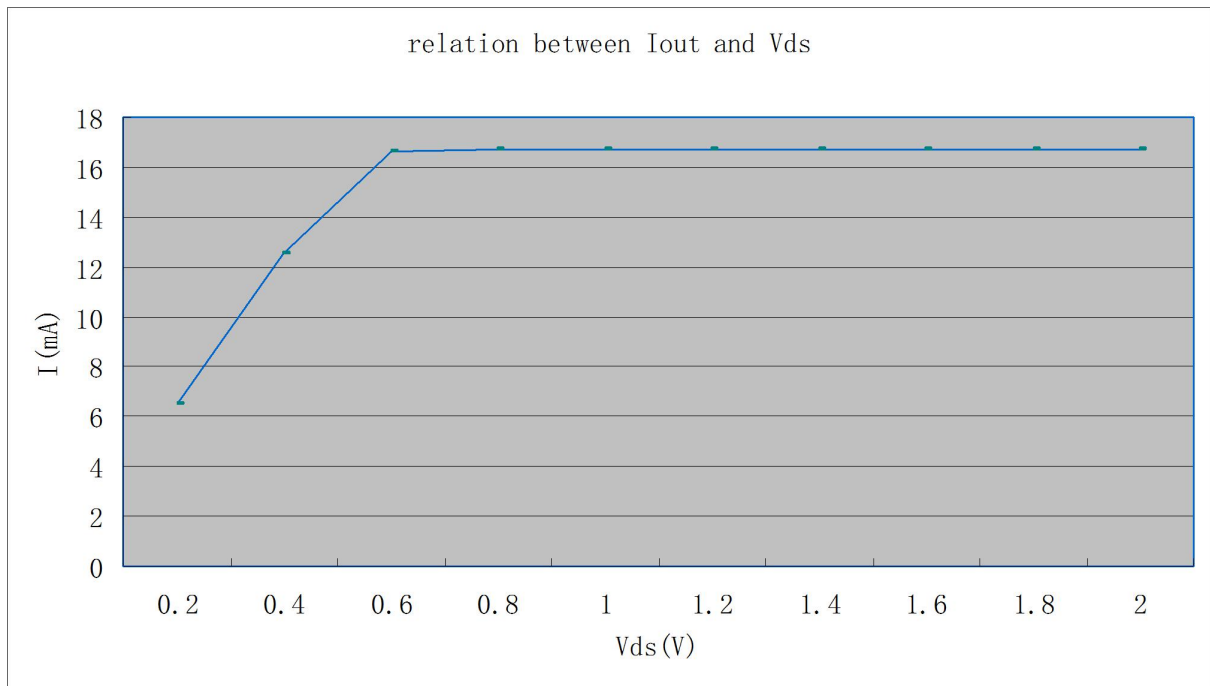

Typical Application circuit diagram

1. Power voltage is 5V

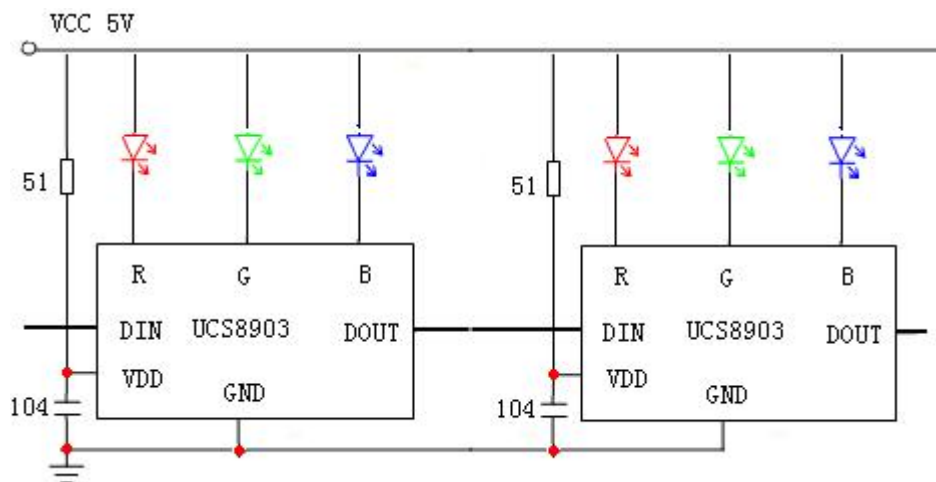

Using constant current mode can be voltage falling at the same time to achieve ideal effect of brightness and color temperature is kept constant.

2. Power voltage is 12V

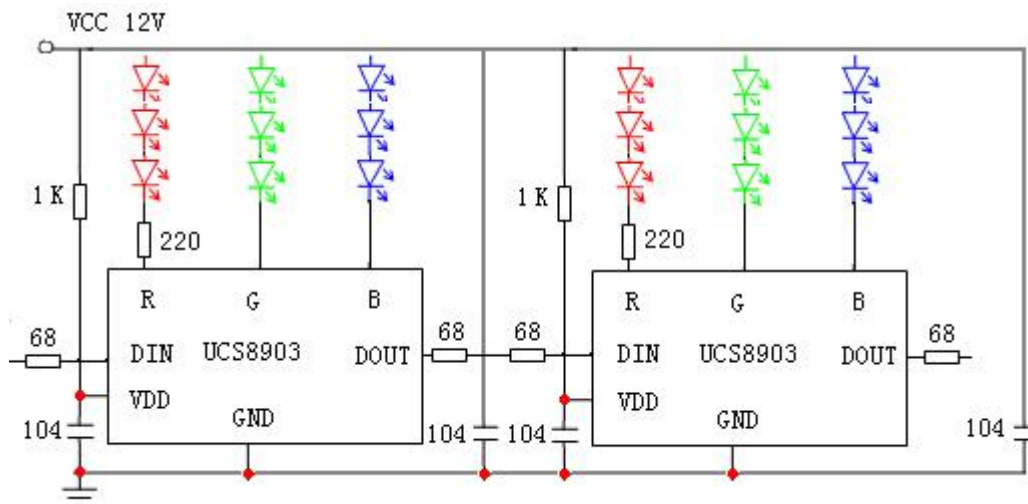

In order to prevent the damage of charged pull plug, when 12 v power supply, Din and Do all the string in a 68-80 ohm resistor for protection

In order to reduce the interference, between each lamps and lanterns of power supply and ground multiple a capacitance of 104 or 105

3. Power voltage is 24V

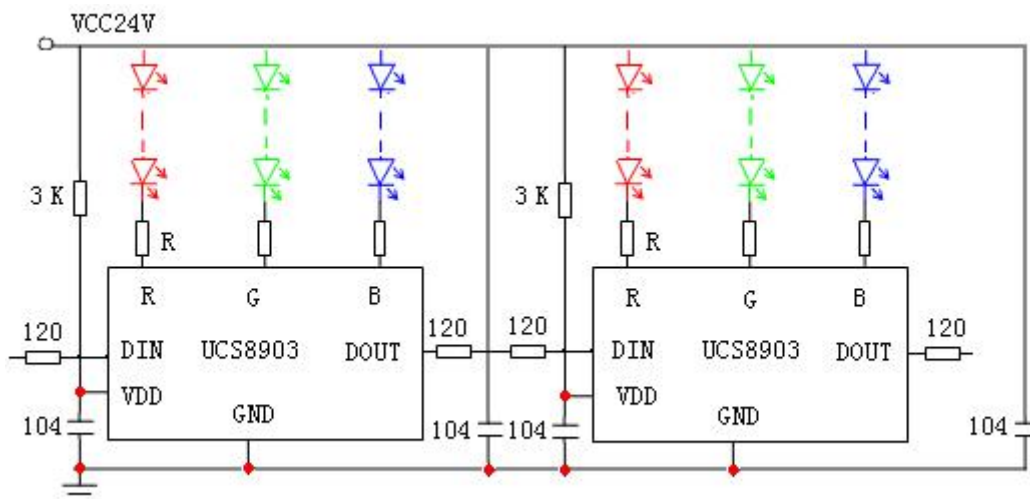

In order to prevent the damage of charged pull plug, when 24 v power supply, Din and Do all the string in a 120 ohm resistor for protection

In order to reduce the interference, between each lamps and lanterns of power supply and ground multiple a capacitance of 104 or 105

4 . Power voltage is 24V

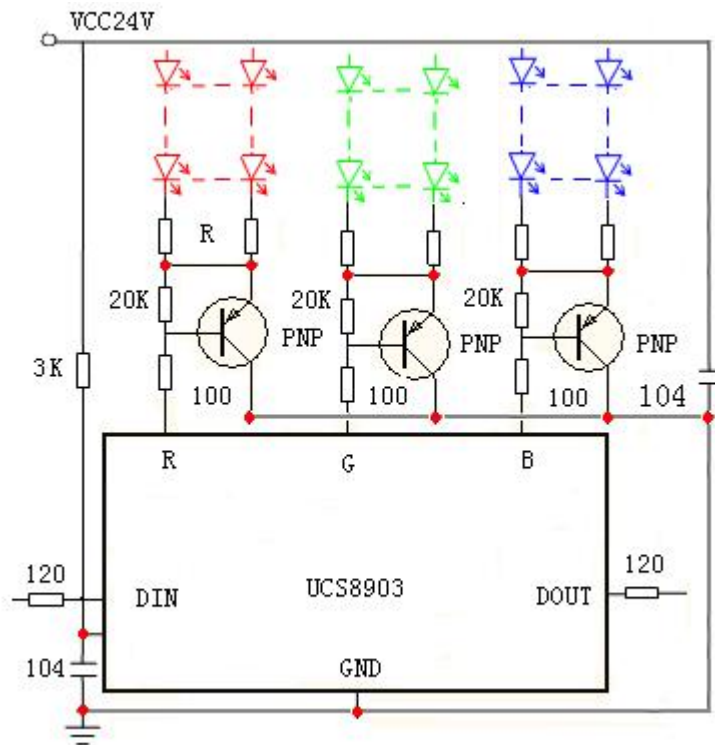

Attention : Shown above for the PNP transistor, 9012,8550 is work
 In order to prevent the damage of charged pull plug, when 24 v power supply, Din and Do all the string in a 120 ohm resistor for protection
 In order to reduce the interference, between each lamps and lanterns of power supply and ground multiple a capacitance of 104 or 105

Vds Definition and values

Vds is the output voltage on the RGB pin。 In order to avoid more than PD, Vds is no more than 4.5 v .The following formula is Vds:

$$Vds = VCC - I * R - N * Vled$$

Attention : I is Each string on the LED current , R is the resistance of LED series , N is the LED series connection number, Vled is the LED voltage

stabilizing voltage characteristic

UCS8903 built-in stabilizer, according to the power supply voltage (VCC) is different, must choose different resistance (R) for step-down voltage, Resistance to select in the table below for reference:

VCC (V)	R(ohm)
5	51-80

12	800-1K
15	1.2K-1.5K
24	2.4K- 3K

package outline drawing AND DIMENSION

SOP 8

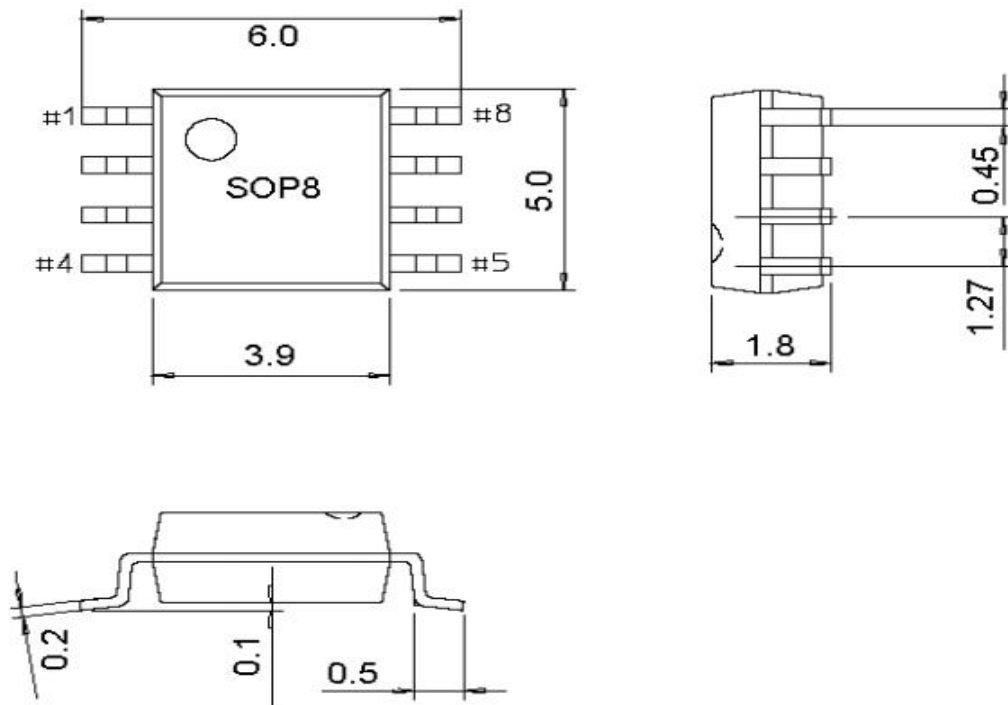

Version

versions	Issuing date	Revised profile
VER1.0	2010-2-20	The first issue
VER2.0	2011-9-11	Layout Adjustment