

# Smart bad point continuation series: 4 channel 65536 level brightness LED driver IC UCS7604

## Product overview

UCS 76 04 Is the intelligent bad point continuous transmission series 4 channel 65536, level gray scale function LED drive control special circuit, internal integrated MCU, digital interface, data latch, LED high voltage drive and other circuits. Through the peripheral MCU control, the separate brightness and cascade control of the chip can realize the color dot matrix luminescence control of the outdoor large screen. Intelligent bad point continued transmission series IC adopted, advanced HPD intelligent error signal identification technology, the channel error signal identification rate reached more than 99%, and also used the patented dual decoding engine, at the same time monitoring two channels, any channel signal problem real-time switch. UCS 7604 RGBW channel output adopts 65535 level gray scale output, with independent current adjustment function of each channel, high precision constant current design, 16K port refresh frequency, so that the picture effect more restore the real color, rich and gorgeous. Excellent product performance, stable and reliable.

## functional characteristics

- Double channel bad point transmission function, fault point signal can continue to be passed down, the overall failure transmission rate of more than 99%
- Advanced HPD intelligent error signal identification technology, the channel fault identification rate of more than 99%
- The patented dual decoding engine simultaneously monitors and decodes two channels, and any problem in the used channel will be switched to normal in real time Channel, and because it is a real-time switch, it is difficult for the human eye to find the abnormal picture process
- Can work normally at any frame frequency
- Advanced channel fault test function, real-time dynamic light on indicates single channel fault and channel short circuit recessive fault in the postpartum test of lamps
- Grayscale level 65536, 8 bit (built-in gamma 2.2, corrected to 16 bit) / 12 / 14 / 16 bit data optional
- Port refresh frequency is 16K
- $\pm 5\%$  high constant current accuracy design
- RGBW current per channel can be set independently
- The applied resistance to set the output current, 0-60 mA
- Data transmission frequencies of 800K / S and 1.6M / S are optional
- The 1 / 2 / 3 / 4 field mode is optional
- Chip VDD built-in 5V voltage regulator, output port pressure maximum 30V
- RGBW channel off, black
- S-AI anti-interference patented technology, which can greatly reduce and filter out radiation interference and conduction interference
- S-Drive drive technology and enhanced receiving technology, greatly enhance the connection distance between points

- Industrial-grade design, stable and reliable

## Foot chart

SOP 8

**Smart bad point continuation series: 4-channel 65536 level  
brightness LED driver IC UCS7604**

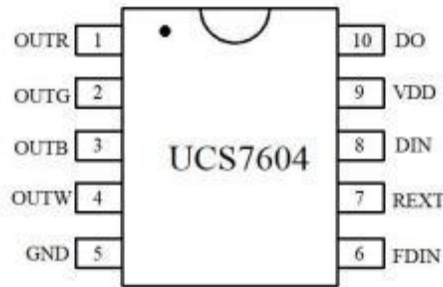

**Footposition instructions**

UCS 7604		
order number	symbol	functional description
1	O UTR	Red (Red) PWM control output
2	O UTG	Green (green) PWM control output
3	O UTB	Blue (Blue) PWM control Outputs
4	O UTW	White (white) PWM control output
5	G ND	landing
6	FDIN	Auxiliary display data input
7	R EXT	Constant current feedback end, connected to the ground resistance to adjust the output current.
8	DI N	Displays the data input
9	VDD	source
10	D O	Displays the data cascade output

Limit parameter (Note 1) (if not otherwise specified,  $T_A = 25^\circ\text{C}$ ,  $V_{SS} = 0\text{V}$ )

parameter	symbol	scope	unit
Logic power supply voltage	$V_{dd}$	6	V
Logical input voltage	$V_i$	$-0.5 \sim V_{dd} + 0.5$	V
OUTR / G / B output port voltage resistance	$V_{ou\ t}$	30	V
VDD port maximum clamp current	$I_{da\ mp}$	25	m A
Thermal resistance of the PN junction to the environment (Note 2)	$R_{\theta\ JA}$	120	$^\circ\text{C}/\text{W}$
Power consumption (Note 3)	$P_d$	600	m W
Work section temperature	$T_j$	$-45 \sim +160$	$^\circ\text{C}$

storage temperature	T <sub>stg</sub>	- 55 ~ + 150	°C
Human Discharge Mode (HBM)	E SD	8000	V

Note 1: The limit parameter means that beyond the working range, the chip may be damaged. Operating within the limit parameters, the device function is normal, but not fully full

Enough for individual performance indicators.

## Smart bad point continuation series: 4-channel 65536 level brightness LED driver IC UCS7604

Note 2:  $R_{\theta JA}$  is measured on a single-layer thermal conductivity test plate under  $T_A = 25^\circ\text{C}$  natural convection according to the JEDEC JESD 51 thermal measurement standard.

Note 3: The maximum power consumption is limited by the chip junction temperature, and the maximum output power will decrease when the ambient temperature increases, which is also determined by the temperature section  $T_{JMAX}$ , the ambient temperature  $T_A$  and  $R_{\theta JA}$ . The maximum allowable power consumption is  $P_D = (T_{JMAX} - T_A) / R_{\theta JA}$  or the lower value given in the limit range

Recommended Scope (unless specified,  $T_A = 40 \sim +85^\circ\text{C}$ ,  $V_{SS} = 0\text{V}$ )

parameter	symbol	minimum	typical case	maximum	unit	test condition
Logic power supply voltage	$V_{DD}$	3	5	5.7	V	-

Electrical parameters (if not otherwise specified,  $T_A = 40 \sim +85^\circ\text{C}$ ,  $V_{SS} = 0\text{V}$ ,  $V_{DD} = 4.5 \sim 5.5\text{V}$ )

parameter	symbol	minimum	typical case	maximum	unit	test condition
clamp voltage	$V_{DD}$	4.8	-	5.5	V	$V_{in} = 12\text{V}$ , with a step-down resistance of 1K
Dynamic current loss	$I_{DDdyn}$	-	2	-	mA	RGBW off / DO off
OUTR / G / B output current	$I_{out}$	-	-	60	mA	REXT and the software settings
Low-level output current	$I_{pol}$	-	25	-	mA	$V_{po} = 0.4\text{V}$
High-level output current	$I_{poh}$	-	17	-	mA	$V_{po} = 4\text{V}$
high level input voltage	$V_{ih}$	0.7V <sub>DD</sub>	-	-	V	The DIN high level
low level input voltage	$V_{il}$	-	-	0.3V <sub>DD</sub>	V	The DIN is at a low-level level
lagging voltage	$V_h$	-	0.35	-	V	$D_{IN}$
OUTR / G / B constant current inflection point voltage	$V_{DS\_1}$	-	0.7	-	V	$I_{out} = 30\text{mA}$
Current offset	$dI_{out}$	-	-	$\pm 5$	%	$V_{ds} = 2\text{V}$
Current offset	%dV <sub>ds</sub>	-	$\pm 0.5$	-	%/V	$I_{out} = 18\text{mA}$ , $1\text{V} < V_{ds} < 3\text{V}$
	%dV <sub>DD</sub>	-	$\pm 0.5$	-	%/V	$I_{out} = 18\text{mA}$ , $4.5\text{V} < V_{DD} < 5.5\text{V}$
	%dT <sub>A</sub>	-	$\pm 3.0$	-	%/°C	$I_{out} = 18\text{mA}$ , $T_A = 40 \sim +85^\circ\text{C}$
input current	$I_i$	-	25/0	-	μA	$D_{in} = 5\text{V} / 0\text{V}$

Switch characteristics (if not otherwise specified,  $T_a = 40 \sim +85^\circ\text{C}$ ,  $V_{ss} = 0\text{ V}$ ,  $V_{dd} = 4.5 \sim 5.5\text{ V}$ )

parameter	symbol	minimum	typical case	maximum	unit	test condition
The OUT port PWM frequency	$F_{\text{pwm } 1}$	-	16	-	KHz	$I_{\text{OUT}} = 18\text{ mA}$ , OUT string with 10 $\Omega$ resistance to 5V
Data transmission frequency	$F_{\text{d } 1}$		800		KHz	
	$F_{\text{d } 2}$		1600		KHz	
propagation delay time	$T_{\text{d } 1}$	-	100	-	ns	$C_1 = 15\text{pF}$ , $D_{\text{in}} \rightarrow D_{\text{out}}$
input capacitance	$C_i$	-	15	-	pF	

# Smart bad point continuation series: 4-channel 65536 level brightness LED driver IC UCS7604

---

## Bad point continuation function

1. UCS 7604 adopts the bad point transmission function of dual channel input. When a failure point occurs, the signal can skip the failure point to continue transmission. In the case of skipping the failure point, the next level IC will automatically identify the signal source and correct the data accordingly, so the picture will not be misplaced.
2. UCS 7604 adopts the advanced HPD intelligent error signal identification technology, and the channel fault identification rate reaches more than 99%. Only in the case of effective identification channel failure can do accurate switch channel, if can identify the fault phenomenon is limited and in some channel failure cannot identify and cannot switch to effective channel or misjudgment and effective channel switch to fault channel, these will reduce the reliability of the bad point transmission function even the failure rate is greater than the single channel transmission. HPD intelligent error signal identification technology can effectively identify the signal changes caused by various faults, and through the real-time comparison of two channels, can maximize the identification of channel faults, to achieve the effect of bad point transmission.
3. UCS 7604 uses the patented dual decoding engine technology to monitor and compare the decoding data of the two channels. The two channels are decoded in real time, and the decoding data of each channel is judged by HPD technology. Then, the judgment results of the two channels are compared and verified to decide whether to switch the channels. This basically avoids unnecessary or even may cause wrong switching, and reduces the resulting failure rate.
4. UCS 7604 can not be limited by the frame frequency, even if the frame frequency is low, it will not cause error switching.
5. UCS 7604 real-time monitoring and contrast two channels, once a channel failure, UCS7604 can real-time recognition and real-time switch channel, and because is a real-time switch, so the eye abnormal images in the process of switching, that is, even any lamps and lanterns in the working process is the use of channel failure, most of the time the eye also see the images.
6. UCS 7604 Failure identification rate is tested by our laboratory by simulating various hard faults and soft faults. In addition to the simple hard fault simulation test, our laboratory will also simulate and test the following soft faults:

Short circuit fault: short circuit resistance resistance from micro short circuit (short circuit resistance 5K) to full short circuit (short circuit resistance 0 Ohm) for each simulated fault

Test in a full range

Circuit fault: open circuit resistance from micro circuit (short circuit resistance 1 Ohm) to full circuit (open circuit resistance 100M)

Test the values in the full range

High and low frequency faults: Each simulated fault is tested at the 1 HZ range to 1M

Note: According to the application scheme and test provided by our company, the overall failure transmission rate is greater than 99%

### **Channel test instructions**

Our company intelligent bad point continuous transmission series IC has the channel test function, can effectively and real-time dynamic identify a single channel fault or 2 channel short circuit fault. Channel test is very important to ensure the quality of the lamps and should not be omitted. UCS 7604 In the channel test, not only can measure the fault of a separate channel, but more importantly, the channel test has added the original short circuit test function of the main and auxiliary channel of our company, which can detect the short circuit phenomenon of the main and auxiliary channel that is not easy to find. In the case of short circuit of the main and auxiliary channels, the normal and stable signal can not be guaranteed, and it is easy to work abnormally or draw in the work



## Smart bad point continuation series: 4-channel 65536 level brightness LED driver IC UCS7604

The phenomenon of surface dislocation jump point, but because the short circuit fault of the main and auxiliary channel has a certain chance to produce abnormal picture, it will not be shown every time, so the screen program test is only used in the production test, so the working state is difficult to maintain the continuous stability of the lamps and lanterns in the later period. Through the special procedure of the channel test, the short circuit fault of the main and auxiliary channel will be clearly identified by the light indication.

Below is the light indication for different faults in the channel test: 25% brightness

- |  |              |   |
|--|--------------|---|
| a . Only the main channel is normal:                       | R<br>bright  | , GBW remains in its original state (black) |
| b . Only the secondary channels are normal:                | G<br>bright  | , RBW remains (black)                       |
| c . The main channel and auxiliary channels are normal:    | RG<br>bright | , BW remains in original state (black)      |
| d . The main channels and auxiliary channels are abnormal: |              | RGBW remains (black)                        |
| e . Main channel and auxiliary short circuit:              |              | RGBW remains (black)                        |

Note 1: UCS 7604 has a real-time response function during the channel test: for example, the main channel is normally red light, once the main channel appears again

When the fault is broken, the red light is extinguished, and when the fault is removed, the red light is immediately lit again. Thus, the fault of any channel is dynamically detected in real time through the test program, and the same is true of the auxiliary channel. That is to say, the channel test and reaction are real-time, so that it is easier to find problems in debugging and production testing, and it can also facilitate maintenance.

Note 2: L-P algorithm is used to identify soft faults at high frequency. In general, hard faults are easy to observe,

However, soft faults (not in continuous presence) are not easy to identify. UCS 7604 The L-P algorithm can identify soft faults at high frequency, and identify them by flashing light.

NOTE 3: If the UCS 7604 compatible test controller has both DO port and FDO port, connect the DO port and FDO port and the port to the DIN and FDIN terminals of the first light, respectively. If the test controller only has the DO port and no FDO port, the DO port of the controller can only connect the DIN of the first light, and cannot connect the DO port to the DIN and FDIN of the first light at the same time, otherwise it is equivalent to the artificial short circuit of DIN and FDIN, and the first light is "black".

### Field mode

field	explain:
1	Receive 1-channel data, corresponding to RGBW, and forward the remaining data
2	Receiving 2 channel data, corresponding to RG, BW, and forward the other data
3	Receiving 3 channel data, corresponding to R, G, B, forward the rest data, and W close
4	Receiving 4 channels of data, corresponding to R, G, B, W, and forward the remaining data

### Gray scale number selection

data bit	gray level:
8	65536 (Internal Gamma 2.2, corrected 16 bit)
12	Level 4096
14	16384

## Smart bad point continuation series: 4-channel 65536 level brightness LED driver IC UCS7604

16 65536
----------

Send frequency selection: 800K and 1.6M are optional

The maximum number of points that can be controlled at different data bits and transmission frequencies: The following table takes 3-color lamps as an example

	800K (30HZ )	800K (60HZ )	.61M (30HZ )	1.6M (60HZ )
8	1111	555	2222	1111
12	740	370	1480	740
14	634	317	1268	634
16	555	277	1110	555

**Note 1:** The number of points in the above table refers to the theoretical maximum points. In fact, the controller is limited by internal resources, and the number of control points is generally less than the maximum points in the above table. Finally, the controller used shall prevail.

**Note 2:** The high speed mode 1.6M has more controllable points, but the connection length is allowed at high transmission rate, and the customer can choose according to the actual demand

### The constant flow value is set

1. UCS 7604 can pair the GND resistance R through the external REXT footREXTSet the RGBW output constant current value, 0-60 mA current  
formula:  $I_0 = 256/RREXT$

2. UCS 7604 can independently set the constant flow values of 4 channels R, G, B and W through the control software, and can set 16-level constant flow values for each channel

### Constant flow curve

UCS 7604 The constant current characteristic is excellent, and the current difference between channels and even between chips is very small.

(1): When the load end voltage changes, the UCS 7604 output current is not affected, as shown in the figure below

(2): As shown in the following figure: between the current Iout of the output port and the voltage Vds curve added to the port, the smaller the Iout current, the smaller the Vds required in the constant current state.

Smart bad point continuation series: 4-channel 65536 level  
brightness LED driver IC UCS7604

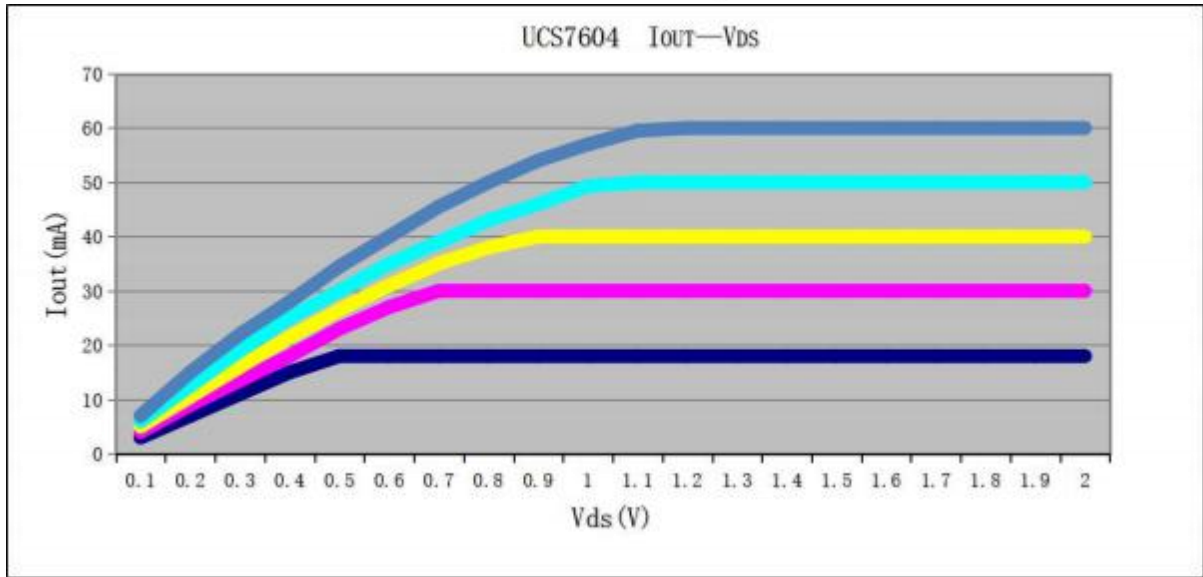

Application line diagram

1. Bad point continuation function application

5V power supply

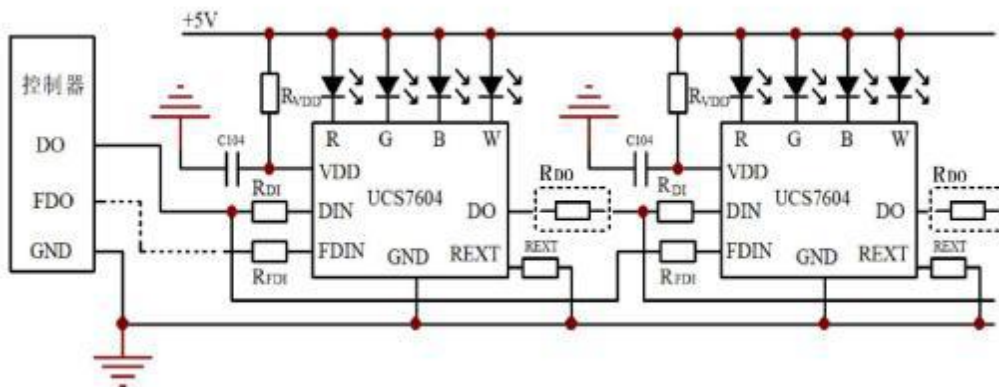

A 24V or 12V power supply

## Smart bad point continuation series: 4-channel 65536 level brightness LED driver IC UCS7604

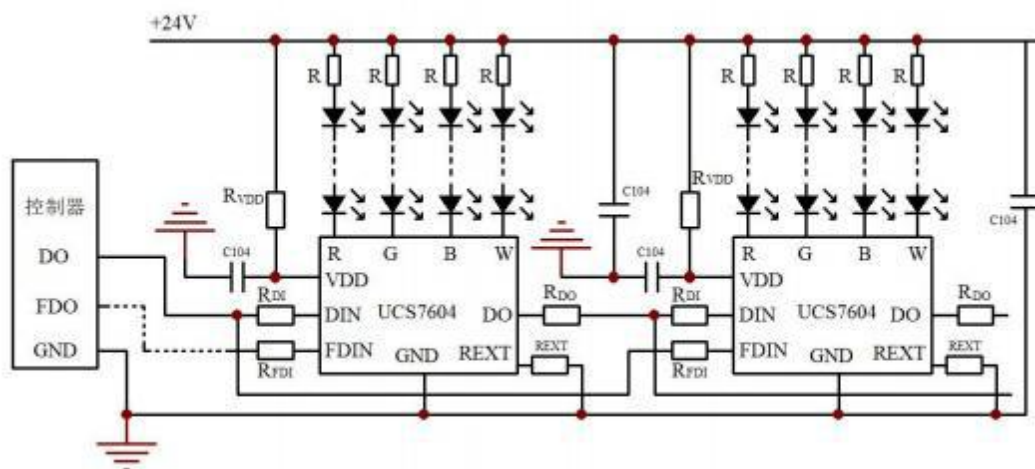

Note 1: In the application, the connection between the controller FDO and UCS 7604 is not connected, so the first point does not have a complete breakpoint transmission function.

Note 2: For 5V, 24V or 12V application, a resistance shall be added at the DIN, FDIN and DO ports as shown in the figure (see the resistance value table of values). In 5V application, if the plate volume is limited, the DO end resistance R<sub>DO</sub> don't add

Note 3; Note that the FDIN resistor R<sub>FDI</sub> shall be connected from (the end of the R<sub>DI</sub> resistance) to the next IC and not the FDIN resistance R<sub>FDI</sub> from (the end of the R<sub>DI</sub> resistor) to the DIN pin)

### Selection table of bad points:

element	24V	12V	5V
R <sub>VDD</sub>	2K (1206 package)	750	100
R <sub>DI</sub>	500	500	500
R <sub>FDI</sub>	500	500	500
R <sub>DO</sub>	120	120	

Note: The above value of R<sub>VDD</sub> is the general recommended value, which is the value after considering the general power bus pressure drop. The customer can value according to the power bus pressure drop, point pull length and static power consumption.  $I_{VDD} = (V_{CC} - V_{DD}) / R_{VDD} > 2.8 \text{ mA}$ , and the larger  $I_{VDD}$ .

### Common cascade applications

5V power supply

**Smart bad point continuation series: 4-channel 65536 level  
brightness LED driver IC UCS7604**

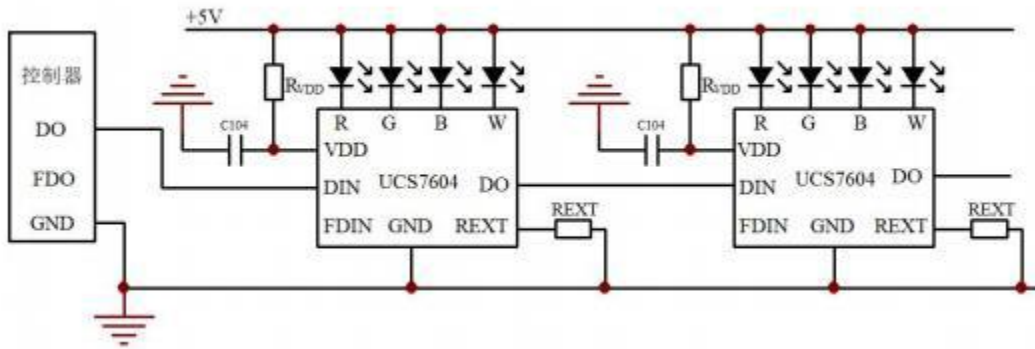

A 24V or 12V power supply

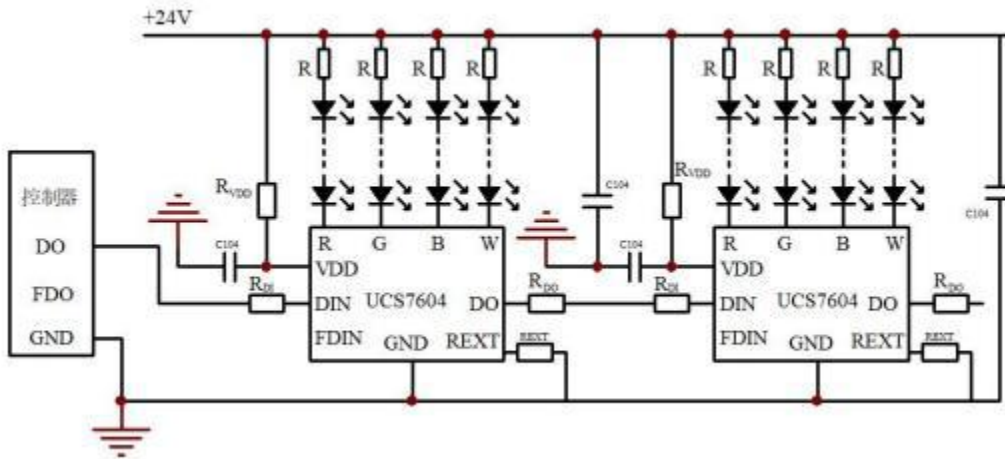

**Component value selection table:**

element	24V	12V	5V
R VDD	2K (1206 package)	750	100
R DI	Either 500 or 120	Either 500 or 120	
R DO	120	120	

Note: The above value of R VDD is the general recommended value, which is the value after considering the general power bus pressure drop. The customer can take the value according to the bus pressure drop, point pull length and static power consumption balance.  $I_{VDD} = (VCC - VDD) / R_{VDD} > 2.8 \text{ mA}$ , and the longer the interpoint pull distance requires a greater  $I_{VDD}$ .

**Package profiles and dimensions**

**Smart bad point continuation series: 4-channel 65536 level  
brightness LED driver IC UCS7604**

SOP 10

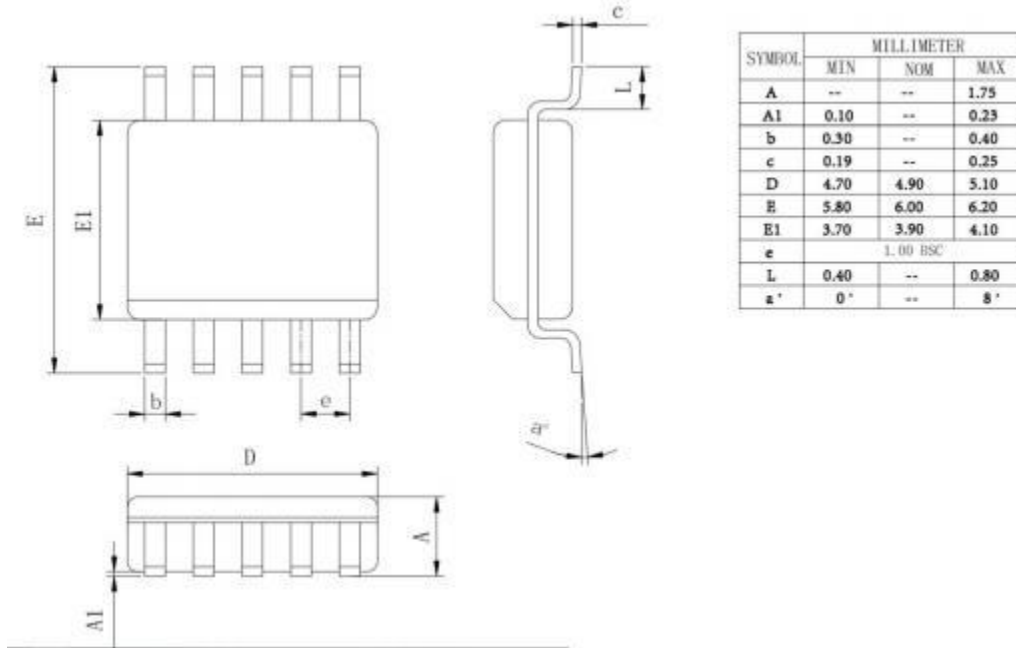

version number

edition	date of issue	Revised profile
VER 1.0	2022-915	First edition release