

Product Overview

UCS5603 is the exclusive 4096 level gray scale three-channel LED drive control circuit equipped with bad point resume function, and it has internal integrated MCU digital interface, data latch, LED high voltage drive and other circuits. It realizes individual brightness of chip through peripheral MCU control, and realizes the light-emitting control of outdoor large-screen color dot matrix by cascade control. The bad dot resume function uses advanced HPD error signal recognition technology, which can recognize more than 99% of the channel error signals. Moreover, a patented dual decoding engine is adopted to simultaneously monitor two channels, and switch in real-time to the normal channel whenever there is a signal problem, so the human eye will not easily find abnormal screen during the process. The RGB channel output of UCS5603 uses 4096 gray scale output, and independent current adjustment function is added to each channel, which, coupled with ± 3 high-precision constant current design, restores the true color of the screen effect and make the screen more vivid and colorful. UCS5603 also uses our proprietary S-Drive drive technology and enhanced reception technology to greatly enhance the distance between points. This product offers great performance and reliable quality.

Featured functions

- Dual-channel bad point resume function: fault point signal can continue to download and the overall bad point resume rate is more than 95%, with no screen dislocation
- Leading HPD error signal recognition technology, with the channel fault recognition rate reaching 99% or more
- Patented dual decoding engine to simultaneously monitor two channels, and switch in real-time to the normal channel whenever there is a signal problem of an operating channel. As the switching is done in a real time manner, human eye will not easily find abnormal screen during the process.
- UCS5603 can work normally at any frame rate
- Advanced channel fault test function:
 1. Real-time response function during channel test: through the test program, dynamically detect any channel failure in a real-time manner, the red light will turn on if the main channel is normal, and the green light will turn on if the auxiliary channel is normal; the corresponding light will not lit in case of channel failure, and the light will be lit if the fault recovers. In this way, real-time monitoring and real-time response are achieved to facilitate the discovery of frequent soft faults.
 2. Dual-channel short circuit test function: When the 2 channels of IC are short circuited, even the pattern program is normal in the production test, instability may occur under a variety of interferences of the engineering environment. Through the UCS5603 dedicated test program, such failure will be effectively identified by the light-off status.

- The RGB output port can reach 4096 gray levels, and the port refresh rate is 2K
- ± 3 high constant current accuracy design
- The current of each RGB channel can be set independently through the software, divided into 16 levels
UCS5603A: 1.5mA-24mA; range: 1.5mA; power-on default current: 18mA
UCS5603B: 3mA-48mA; range: 3mA; power-on default current: 36mA

3-Channel 4096 gray scale bad point resume LED driver IC UCS5603

- UCS5603 data transmission frequency: 800K / s. When the screen refresh rate requirement is 30 frames / sec, it can cascade 740 points; when the screen refresh rate requirement is 60 frames / sec, it can cascade 370 points. Lower frame rate requirements can cascade more points
- The chip VDD has built-in 5V regulator, and the output port withstand voltage is 30V
- Power-on RGB channels will all be lit, and the brightness is 50%
- Low-voltage enhancement technology design allows UCS5603 to work normally at as low as 2.5V, significantly reducing the interference caused by power fluctuations
- Patented S-AI anti-interference technology can significantly reduce and filter out radiation interference and conduction interference
- S-Drive drive technology and enhanced reception technology can greatly enhance the distance between points
- Industrial design that is stable and reliable

Simple application diagram

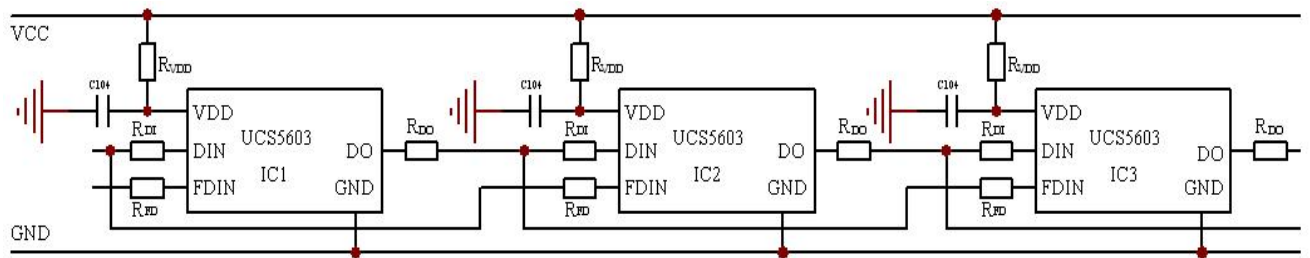

Pin layout (SOP8)



Pin description

UCS5603		
No.	Symbol	Function Description
1	OUTR	Red, PWM Control Output
2	OUTG	Green, PWM Control Output

3-Channel 4096 gray scale bad point resume LED driver IC UCS5603

3	OUTB	Blue, PWM Control Output
4	DOUT	Display Data Cascade Output (800K)
5	DIN	Display Data Input (800K)
6	GND	Ground
7	FDIN	Auxiliary Display Data Input (800K)
8	VDD	Power Supply

Maximum rating (Unless otherwise specified, Ta = 25 ° C, Vss = 0V)

Parameter	Symbol	Range	Unit
Logic supply voltage	Vdd	6.5	V
Output port withstand voltage	Vout	30	V
Logic input voltage	Vi	-0.5 ~ Vdd + 0.5	V
Operating temperature	Topt	-45 ~ + 85	°C
Storage temperature	Tstg	-55 ~ + 150	°C
Antistatic	ESD	8000	V
Rated output power	Pd	400	mW

Recommended working range (Unless otherwise specified, Ta = -40 ~ + 85 ° C, Vss = 0 V)

Parameter	Symbol	Minimum value	Characteristic value	Maximum value	Unit	Test Conditions
Logic supply voltage	Vdd	2.5	5.5	6	V	-
High level input voltage	Vih	0.7Vdd	-	Vdd	V	-
Low level input voltage	Vil	0	-	0.3Vdd	V	-
Output port withstand voltage	Vout		28	30	V	-

Electric parameter (Unless otherwise specified, Ta = -40 ~ + 85 ° C, Vss = 0 V, Vdd = 4.5 ~ 5.5 V)

Parameter	Symbol	Minimum value	Characteristic value	Maximum value	Unit	Test Conditions
Low level output current	Iout	1.5	18	24	mA	R, G, B-UCS5603A
Low level output current	Iout	3	36	48	mA	R, G, B-UCS5603B
Low level output current	Ido	20	-	-	mA	Vo = 0.4 V, Dout
Input Current	Ii	-	-	±1	μA	

3-Channel 4096 gray scale bad point resume LED driver IC UCS5603

High level input voltage	V _{ih}	0.7V _{dd}	-		V	D _{IN} , SET
Low level input voltage	V _{il}	-	-	0.3V _{dd}	V	D _{IN} , SET
Hysteresis voltage	V _h	-	0.35	-	V	D _{IN} , SET
Current offset (between channels)	dI _{out}		±1.5	±3.0	%	V _{ds} =1V, I _{out} =18mA
Current offset (inter-chip)	dI _{out}		±3.0	±5.0	%	V _{ds} =1V, I _{out} =18mA
Current offset VS-V _{ds}	%dV _{ds}		±0.1	±0.5	%/V	1V<V _{ds} <3V
Current offset VS-V _{dd}	%dV _{ds}		±1.0	±2.0	%/V	4.5V<V _{dd} <5.5V
Dynamic current loss	IDD _{dyn}			1	mA	No load
Power consumption	PD			300	mW	(T _a =25°C)
Thermal resistance	R _{th(j-a)}		80	190	°C/W	

Switching characteristic (Unless otherwise specified, T_a = -40 ~ +85 °C, V_{ss} = 0V, V_{dd} = 4.5 ~ 5.5V)

Parameter	Symbol	Minimum value	Characteristic value	Maximum value	Unit	Test conditions
Oscillation frequency	FOSC1	-	800	-	KHz	V _{dd} =5V
	FOSC2	-	20	-	MHz	V _{dd} =5V
Transmission delay time	T _{flz}	-	-	300	ns	C _l = 15 pF, D _{IN} → D _{OUT} , R _l = 10 kΩ
Fall time	T _{thz}	-	-	120	μs	C _l = 300 pF, OUTR/OUTG/OUTB
Data transfer rate	F _d	800	-	-	Kbps	Duty cycle 50%
Input capacitor	C _i	-	-	15	pF	-

Power on status description

After power on, RGB channels will output at 50% gray scale, and RGB light be will lit; constant current: 18mA (UCS5603A), 36mA (UCS5603B)

Bad point resume function

1. UCS5603 adopts the bad point resume function of dual-channel input. In case of a bad point, the signal can skip the point and continue to download, and the next level IC will automatically identify the signal source and correct data accordingly, so the screen will not be dislocated.

2. UCS5603 adopts the leading HPD error signal recognition technology with the channel fault recognition rate reaching 99% or more. Accurate channel switch is only possible when the channel fault is effectively identified. If fault identification is limited, it is hard to switch to the effective channel, or even worse, the effective channel may be switched to fault channel due to wrong judgement, which will reduce the reliability of bad point resume function and even increase the failure rate to a value greater than the single channel transmission. The leading HPD signal recognition technology can effectively identify signal changes caused by various faults, and identify channel failure by real-time comparison of the two channels, thus it can guarantee the best possible effect of bad point resume function.
3. UCS5603 uses a patented dual decoding engine technology to monitor and compare the decoding data of two channels at the same time. As the 2 channels are decoded in a real-time manner, the data are analyzed through the HPD technology, and the results are verified and compared to determine whether to switch a channel or not. This basically avoids unnecessary and even erroneous switching, thus it can reduce failure rate caused thereby.
4. UCS5603 is not be limited by frame rate, thus low frame rate will not cause erroneous switch.
5. UCS5603 monitors and compares two channels in a real-time manner. In case of a channel failure, UCS5603 can identify the failure and conduct real-time channel switching, and because it is real-time switching, the human eye will not easily detect screen abnormality during the switching process. In other words, if a channel goes wrong when a lamp is working, the human eye will not observe the screen abnormality most of the time..
6. UCS5603 fault recognition rate is obtained by our company's laboratory through the testing of a variety of simulated hard and soft faults. In addition to the testing of simple hard faults, the company will also simulate and test the following soft faults:

Short-circuit fault: Each simulated fault will test the full range of short-circuit resistance values, from micro short-circuit (short-circuit resistance of 5K) to full short-circuit (short-circuit resistance of 0 ohm)

Breaking fault: Each simulated fault will test the full range of break-circuit resistance values, from micro break-circuit (break-circuit resistance of 1 ohm) to full break-circuit (break-circuit resistance of 100M)

High and low frequency faults: Each simulated fault will test the full range of frequency from 1HZ to 1M.

Note: The overall failure resume rate is greater than 95%

Note: UCS5603 cannot rule out the risk of bad point resume failure or screen dislocation under rare circumstances,

Test instruction

In the actual production test, it is recommended to divide the test into the following two steps:

1. **Regular test:** The controller sends the R-G-B-black four-color jump program or other program that can simultaneously detect the working status and issues such as color missing or light leak. Besides the identification of lamp failures, this test can also lay a foundation for the following channel test.
2. **Single channel fault and 2-channel short-circuit test:** use channel test program to effectively and dynamically identify single channel fault or 2-channel short-circuit fault in a real time manner, see the following table (the brightness is 25%)
 - a. Only the main channel is normal: R bright, GB remain at the original state (black)
 - b. Only auxiliary channel is normal: G bright, RB remain at the original state (black)
 - c. Both the main channel and auxiliary channel are normal: RG bright, B remains at the original state (black)
 - d. Both the main channel and auxiliary channel are abnormal: RGB remain at the original state (black)
 - e. The main channel and auxiliary channel are short-circuited: RGB remain at the original state (black)

Note 1: While carrying out the second step of test, the test controller should send three all-black screens (turn off RGB) first before sending a special test program, only by doing so can the correct lighting status be observed. This is the meaning of the "original state (black)" described above.

Note 2: In the second step of test, UCS5603 is equipped with real-time response function: For example, the red light is on when the main channel is normal, with the power supply kept on, the red light will go out in case of main channel fault, and immediately lit again in case of fault removal. This allows the test program to dynamically detect any channel failure in a real-time manner, and it also applies to the auxiliary channel.. In other words, channel testing and response are both real-time, so it is more likely to find out problems during the debugging and production test, and it also makes maintenance easier.

Note 3: In the second step of test, the L-P algorithm is adopted to identify soft faults at higher frequencies. In general, hard faults are easy to observe, but soft faults (non-continuous) are not easily recognized. The UCS5603 uses the L-P algorithm to identify soft faults at higher frequencies and mark these faults with flashing lights.

Note: If the test controller compatible with the UCS5603 has both DO port and FDO port, it is OK to respectively connect the DO port and the FDO port with the DIN terminal and FDIN terminal of the first lamp. If the test controller only has DO port, and it has no FDO port, the DO port cannot be connected to the DIN and FDIN of the first light, otherwise, the first light will not give normal light instructions in the test mode. Remember, the controller DO port can only be connected to the DIN of the first lamp.

Instructions on long distance wire

UCS5603 adopts S-Drive technology that has a strong wire-drawing capacity. The wire length between points can be greater than 10 meters, and the number of points is not limited. To get longer wire, the following

specifications should be observed:

1. Please design the external parameters in accordance with the manual, and add capacitor between the VCC and GND, see the application diagram for details.
2. The voltage at the sending point of a long wire shall not be too low. For 24V power supply lamps, the voltage should not be less than 21V; for 12V power supply lamps, the voltage should not be less than 10V.
3. Long wire can use 0.3mm or greater copper wire, but aluminum wire, iron wire or copper clad aluminum wire is not acceptable.

Constant current value setting of each color

1. UCS5603 allows independent constant current setting of R,G and B channels, and each channel can set 16 levels of constant value, with the value range as
 UCS5603A: 1.5mA-24mA, range: 1.5mA
 UCS5603B: 3mA-48mA, range: 3mA

The following table shows the constant current values of the 16 levels

R/G/B	UCS5603A Constant current value (mA)	UCS5603B Constant current value (mA)
1	1.5	3
2	3	6
3	4.5	9
4	6	12
5	7.5	15
6	9	18
7	10.5	21
8	12	24
9	13.5	27
10	15	30
11	16.5	33
12	18	36
13	19.5	39
14	21	42
15	22.5	45
16	24	48

2. Through the independent RGB channel constant current value setting function, the RGB lamp beads can be configured with different current ratios to achieve the actual white balance effect, which, coupled with 4096 levels high brightness, can help realize high-quality picture effects.
3. Through the constant current value setting function, different current can be set by software according to the actual needs of lamp (power or brightness).

Constant current curve

UCS5603 has excellent constant current characteristics, with minimum current variation between channels or even chips.

(1): the maximum current error between channels is less than $\pm 1.5\%$, and the maximum current error between chips is less than $\pm 3\%$.

(2): Load terminal voltage change will not affect UCS5603 output current, as shown below

(3): The relationship between the current I_{out} at the output port of UCS5603 and the voltage V_{ds} at the port is as shown below, as I_{out} gets smaller, the V_{ds} at the constant current state also gets smaller.

1.UCS5603A

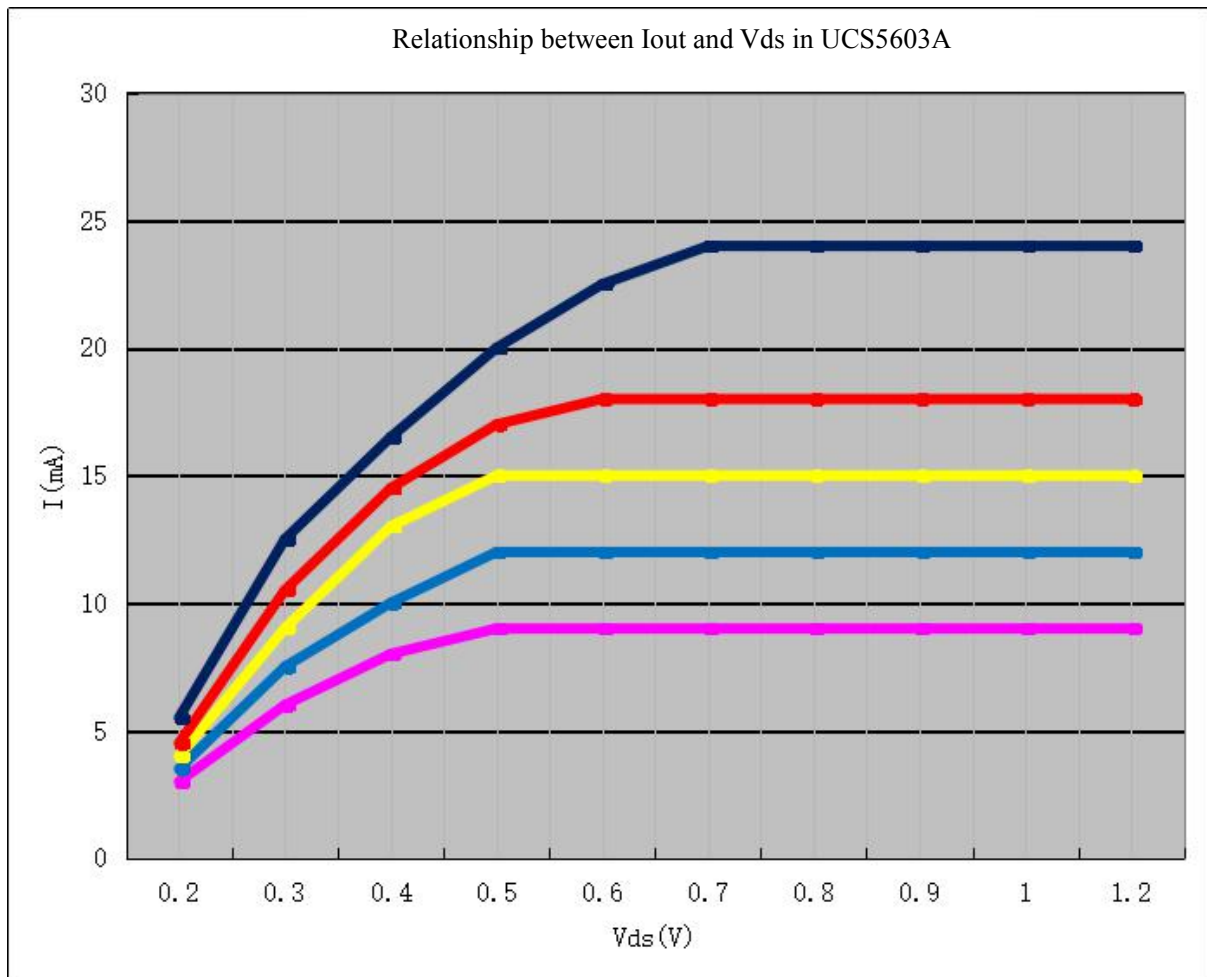

2. UCS5603B

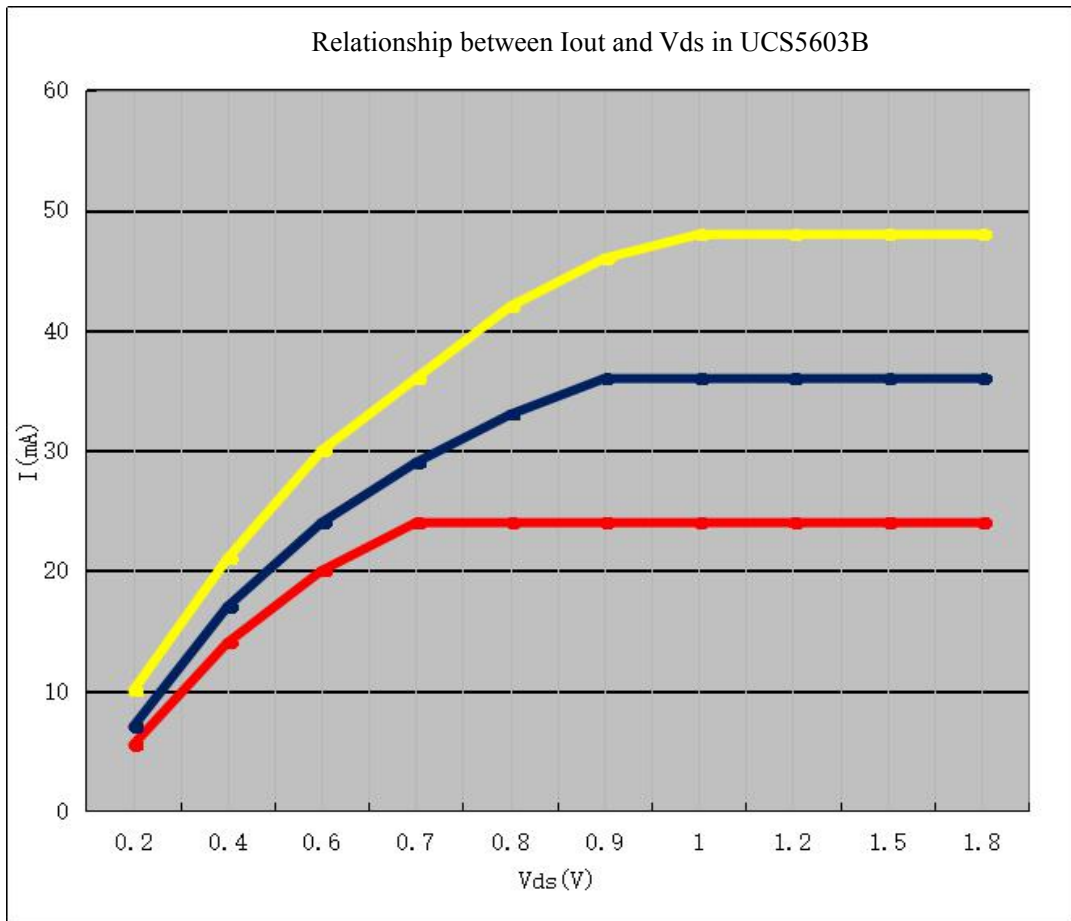

Application

Application circuit diagram

1. 5V power supply, 1 LED in series

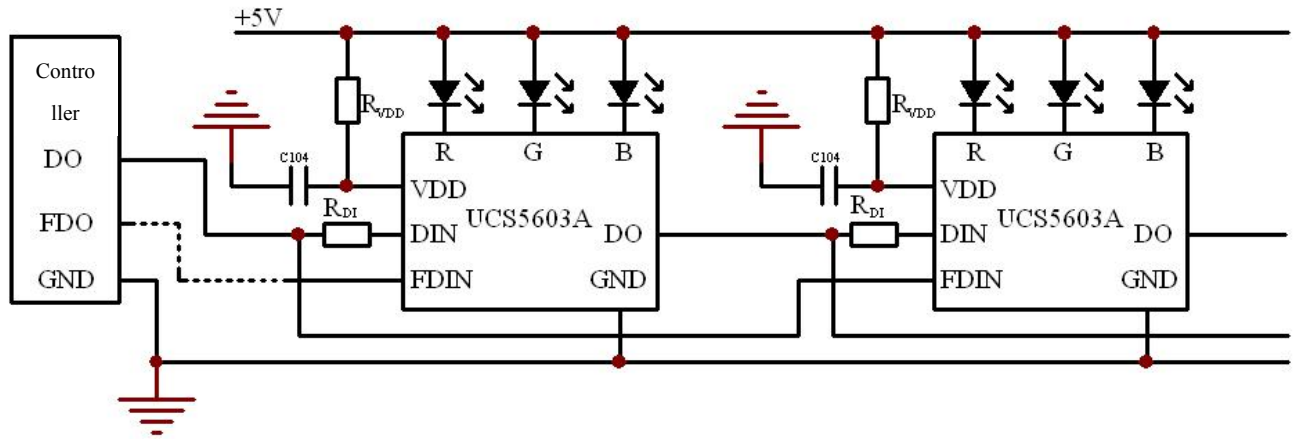

Note 1: In the application, the connection between the controller FDO and UCS5603 can be disconnected, at this time, the first point does not have the complete breakpoint resume function.

Note 2: In 5V application, a protective resistor R_{DI} still must be equipped at the port of DIN (see the following components value selection table for the resistance value)

Note 3: Note that the connection shall be between the other end (the DIN pin end that connects with R_{DI} resistor) and the FDIN of the next IC, rather than directly connecting the DIN pin with the FDIN of the next IC

2. 12V power supply, 3 LEDs in series

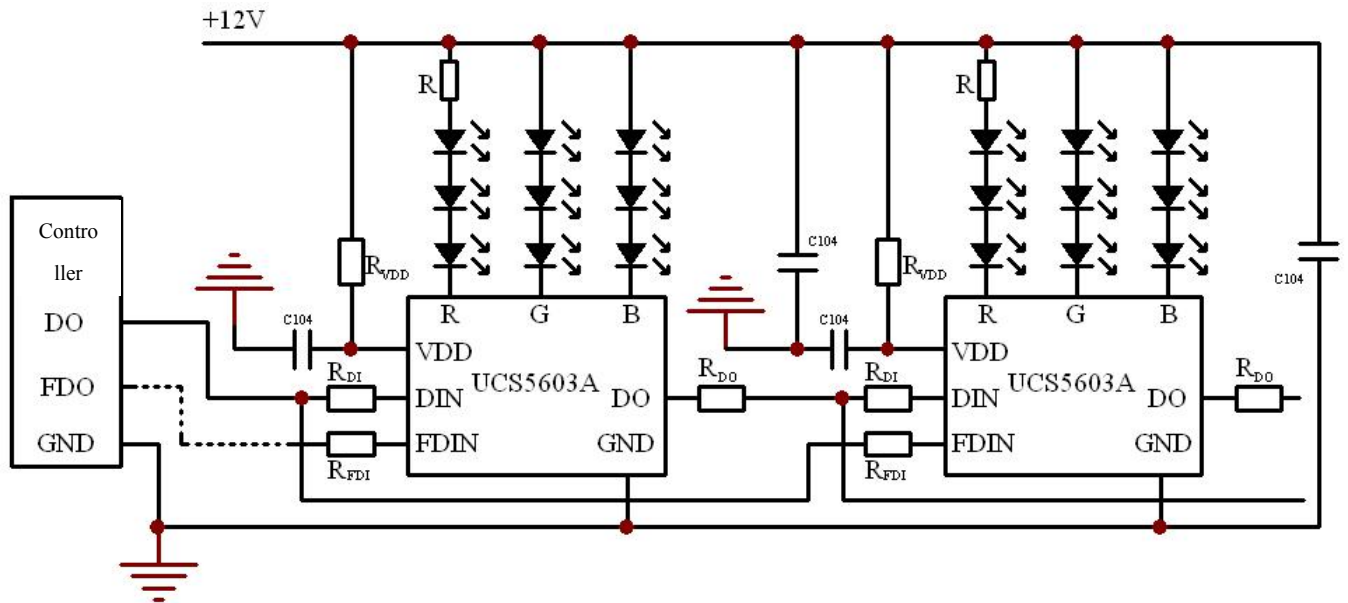

- Note 1: In the application, the connection between the controller FDO and UCS5603 can be disconnected, at this time, the first point does not have the complete breakpoint resume function.
- Note 2: In 12V application, a protective resistor must be equipped respectively at the port of DIN, FDIN and DO, as shown in the figure (see the following components value selection table for the resistance value)
- Note 3: Note that the connection shall be between the other end (the DIN pin end that connects with R_{DI} resistor) and the FDIN protection resistor R_{FDI} of the next IC, rather than directly connecting the DIN pin with the FDIN protection resistor R_{FDI} of the next IC
- Note 4: In addition to connect a 104 capacitor in parallel between the VDD and GND of IC, a 104 capacitor shall also be connected in parallel between the VCC and GND to reduce ground surge interference.

3. 24V power supply, 4-6 LED in series

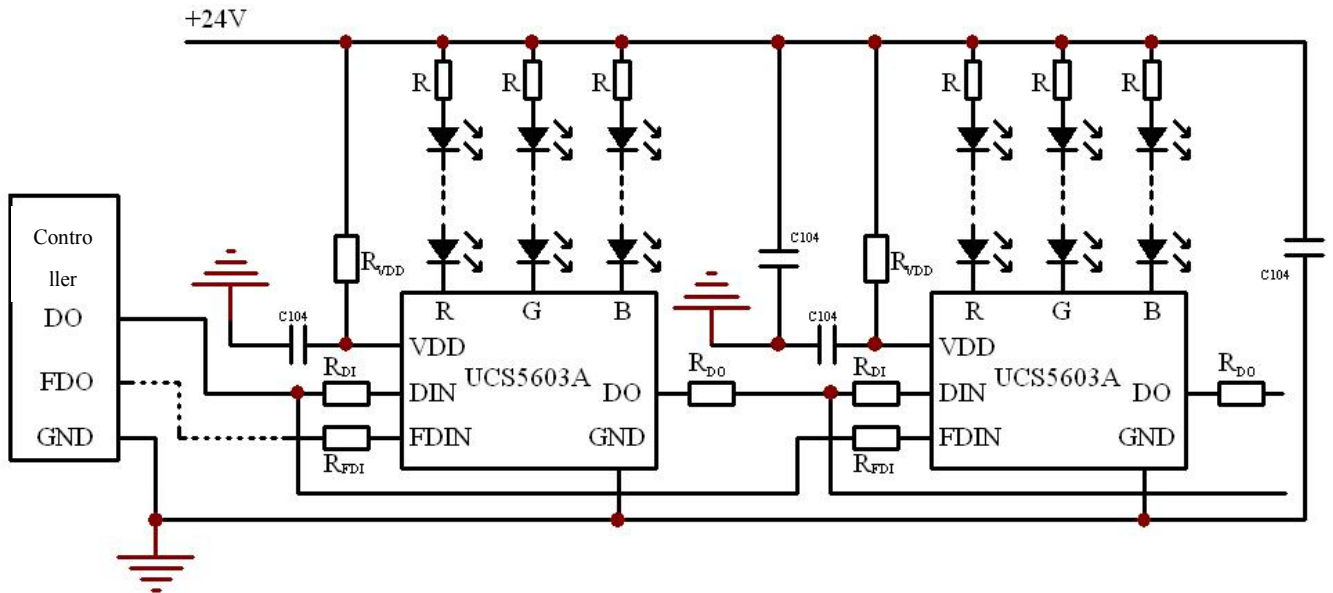

- Note 1: In the application, the connection between the controller FDO and UCS5603 can be disconnected, at this time, the first point does not have the complete breakpoint resume function.
- Note 2: In 24V application, a protective resistor must be equipped respectively at the port of DIN, FDIN and DO, as shown in the figure (see the following components value selection table for the resistance value)
- Note 3: Note that the connection shall be between the other end (the DIN pin end that connects with R_{DI} resistor) and the FDIN protection resistor R_{FDI} of the next IC, rather than directly connecting the DIN pin with the FDIN protection resistor R_{FDI} of the next IC
- Note 4: In addition to connect a 104 capacitor in parallel between the VDD and GND of IC, a 104 capacitor shall also be connected in parallel between the VCC and GND to reduce ground surge interference.

4. 24V power supply, LED 4-6 in series, 2 in parallelism (UCS5603B)

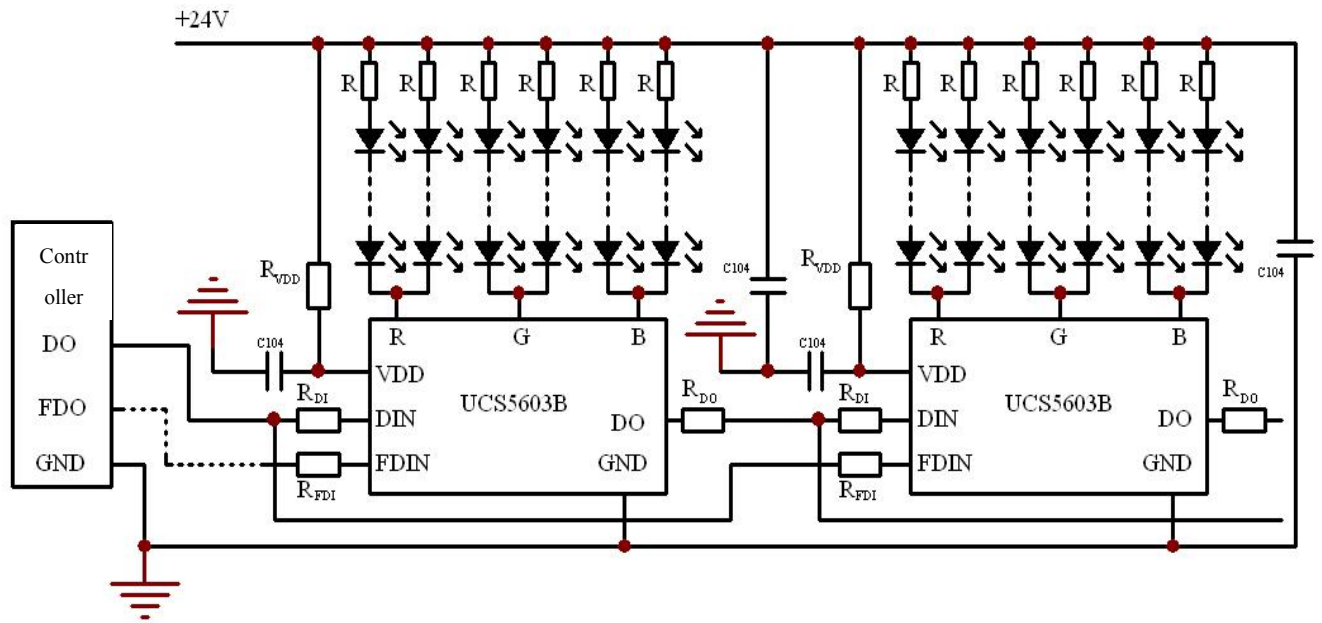

Note 1: In the application, the connection between the controller FDO and UCS5603 can be disconnected, at this time, the first point does not have the complete breakpoint resume function.

Note 2: In 24V application, a protective resistor must be equipped respectively at the port of DIN, FDIN and DO, as shown in the figure (see the following components value selection table for the resistance value)

Note 3: Note that the connection shall be between the other end (the DIN pin end that connects with R_{DI} resistor) and the FDIN protection resistor R_{FDI} of the next IC, rather than directly connecting the DIN pin with the FDIN protection resistor R_{FDI} of the next IC

Note 4: In addition to connect a 104 capacitor in parallel between the VDD and GND of IC, a 104 capacitor shall also be connected in parallel between the VCC and GND to reduce ground surge interference.

Components value selection table: To better implement the bad point resume function, customers are recommended to select values according to the following table

Component	24V	12V	5V
R_{VDD}	2.2K (1206 package)	750	100
R_{DI}	500	500	500
R_{FDI}	500	500	
R_{DO}	120	120	

SOP8

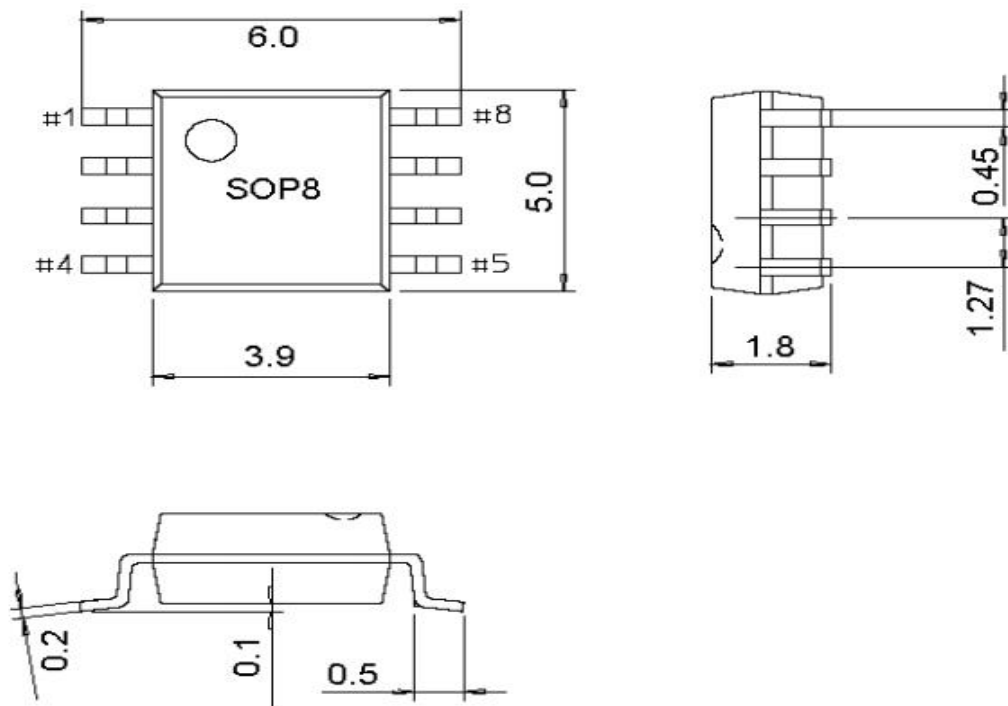

Version number

Version	Issue date	Revision Introduction
VER1.0	2016-6-25	Original Issue
VER1.1	2017-4-5	Content correction