

**功能描述: Function description**

UCS512A1是512差分信号并联协议LED驱动芯片，可选择1/2/3/4通道高精度恒流输出，并带解码转发功能，可以将DMX512信号转换成单线归零码信号从D0口输出，直接控制我公司19及29系列IC，可转发192个通道数据。UCS512A1 解码技术精准解码DMX512信号，可兼容并拓展512协议信号，UCS512A1对传输频率在200K-500K以内的DMX512信号完全自适应解码，无需进行任何速度设置，寻址可达4096通道。UCS512A1内置E2PROM，无需外接，同时支持在线写码，可通过地址写码线实现100米（点间距）\*1024（UCS512 级联点数）一次性在线写码。芯片提供4个耐压30V以上的可达60毫安的高精度恒流输出通道，并且藉由1个外接电阻来设定电流的输出大小。UCS512A1有PWM反极性降频输出功能，此功能适合外挂三极管，MOS管或大电流恒流驱动IC的应用。高端口刷新率，大幅提高画面刷新率。UCS512A1具有多字段选择功能，可将多个恒流输出通道短路来扩大电流驱动能力。它主要为建筑物装饰和舞台灯光效果LED 照明系统而设计，适合于需要并行连接的 LED 照明系统，某一个芯片的异常完全不影响其他芯片的正常工作，维护简单方便。数量

UCS512A1 is a 512 differential signal parallel protocol LED driver chip , can select the 1/2/3/4 channel high precision constant current output. With decode and forward function, DMX512 signal can be converted into a single line return to zero code signal, 192 channel data can be forwarded, output from the DO port to direct control of my company's 19 and 29 series IC,

UCS512A1 decoding technology to accurately decode the DMX512 signal, can be compatible and expand the 512 protocol signal. DMX512 signal the transmission frequency of the 200K-500K fully adaptive decoding, without any speed settings. Addressing up to 4096 channels

UCS512A1 built-in E2PROM, no need to add, while supporting online write code, can be achieved through the address code line to achieve 100 meters (point spacing) \*1024 (UCS512A1 cascade ) one-time online write code

Chip provides 4 output channel of above 30V voltage up to 60 mA high precision constant current , and by an external resistor to set the output size of the electric current. UCS512A1 is a multi field selection function, the multiple channel constant flow output short path to expand the current driving capability

It is mainly for building decoration and stage lighting effects LED lighting system design, LED lighting system suitable for parallel connection, The exception of a certain chip does not affect the normal work of other chips, maintenance is simple and convenient.

**特性: characteristic**

- 兼容并扩展DMX512(1990)信号协议; Compatible and extended DMX512 (1990) signal protocol
- 控制方式: 差分信号并联 Control mode: Differential signal parallel
- 对信号传输速率200K ~500kbps的DMX512信号可完全自适应解码  
DMX512 signal the transmission frequency of the 200K-500K fully adaptive decoding
- 无需外接E2PROM, 无需外加485. No external E2PROM, no additional 485
- 内置485模块具有差分信号分辨率高, 差分输入阻抗大的优点, 可大大加强带载能力  
The built-in 485 module has the advantages of high differential signal resolution and high differential input impedance, which can greatly enhance the load carrying capacity.
- 解码转发拓展功能, 可通过D0端口拓展控制我公司29系列IC, 最大64个点(192个通道)。  
Decode forward to expand the function, through the D0 port to expand the control of my company 29 series IC, Maximum 64 points (192 channels)
- 支持在线写码, 可先安装, 再写码  
Support online write code, can be installed first, and then write code
- 双E2地址码备份模式, 一个E2损坏也不影响地址码读取  
Double E2 address code backup mode, a E2 damage does not affect the address code read
- 内置5V稳压管, 输出通道耐压30V  
Built in 5V voltage regulator tube, the output channel can withstand voltage 30V
- R/G/B/W 四位恒流输出通道, 端口刷新率3.39KHz(中心值)

R/G/B/W four constant current output channel, channel refresh rate : 3.39KHz (Center value)

- 外置输出恒流可调电阻，每通道电流范围3~60mA;  
External output constant current adjustable resistance, current range per channel 3~60mA;
- $\pm 3\%$ 芯片间电流差异值  $\pm 3\%$  inter chip current difference value
- 多字段选择功能，扩大电流输出能力  
Multiple field selection function, extended current output capability
- PWM 选择端可选择反极性降频功能，降频后，端口刷新率为850HZ（中心值），适合于外接大电流驱动器件  
PWM Port can choose reverse polarity drop frequency function, the port refresh rate is drop to 850HZ (center value), Suitable for external high current drive
- 上电后自检，自检完成后亮白灯，写码成功后，蓝灯亮  
Self checking bright white lights after Power on , after the success of the Write code, the blue light
- 写码完成后新地址即刻生效，无需重新上电  
After the completion of the new address immediately take effect, no need to re power
- 工业级设计，性能稳定 Industrial grade design, stable performance

#### 应用范围: Application range:

点光源，线条灯，洗墙灯，舞台灯光系统，室内外视频墙，装饰照明系统

Point light source, line lamp, wall lamp, stage lighting system, indoor and outdoor video wall, decorative lighting system

#### 封装形式: Footprint

SOP16 (UCS512A1) , SSOP16L (UCS512SS)

2 种封装管脚顺序位置相同 The 2 package pins are in the same order position

#### 脚位图: pin assignment

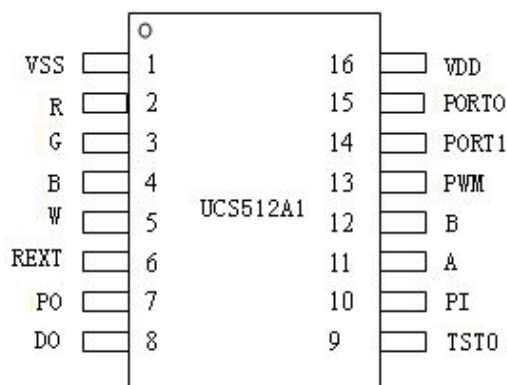

## 脚位说明: Pin Description

UCS512A1/UCS512SS		
序号 Serial number	符号 Symbol	功能描述 describe
1	GND	
2~5	RGBW	PWM 输出端口 PWM output port
6	REXT	恒流反馈端, 对地接电阻调整输出电流大小 Constant current feedback end, the resistance of the ground to adjust the output current size
7	PO	地址写码线输出 Address write code line output
8	DO	解码转发通道, 可连接我公司 29 系列 IC Decode and forward channel, can connect my company 29 series IC
9	TST	测试脚, 内置下拉 Test pin, built-in drop
10	PI	地址写码线输入, 内置上拉 Address write code line input, built-in pull
11	A	差分信号, 正 Differential signal A
12	B	差分信号, 负 Differential signal B
13	PWM	输出极性选择, 一般悬空, 连接 VDD 后输出极性相反, 同时端口刷新频率降为 800HZ Output polarity selection, general suspended, The opposite of output polarity after connecting VDD, the port refresh rate dropped to 800HZ
14	PORT1	字段选择, 内置下拉 Field selection, built-in drop
15	PORT0	字段选择, 内置下拉 Field selection, built-in drop
16	VDD	电源端, 内置 5V 稳压管 Power supply end, built-in 5V voltage regulator tube

## 最大额定值 Maximum rating (Ta = 25 °C, Vdd = 5V)

参数 parameter	符号 Symbol	范围 Range	单位 Unit
逻辑电源电压 Logic supply voltage	Vdd	+ 5.5 ~ + 6.5	V
输出端口耐压 Output port withstand voltage	Vout	30	V
逻辑输入电压 Logic input voltage	Vi	-0.5 ~ Vdd + 0.5	V
工作温度 working temperature	Topt	-45 ~ + 85	°C
储存温度 Storage temperature	Tstg	-55 ~ + 150	°C

## DMX512 decoding and driving IC

UCS512A1

抗静电 Anti static	ESD	8000	V
额定输出功率 Rated output power	Pd	400	mW

推荐工作范围 Recommended operating range ( $T_a = -40 \sim +85^\circ\text{C}$ ,  $V_{dd} = 5\text{V}$ )

参数 parameter	符号 Symbol	最小 minimum	典型 typical	最大 maximum	单位 Unit	测试条件 Test condition
逻辑电源电压 Logic supply voltage	Vdd	2.6	5.5	6.5	V	-
高电平输入电压 High level input voltage	Vih	0.7Vdd	-	Vdd	V	-
低电平输入电压 Low level input voltage	Vil	0	-	0.3Vdd	V	-
输出端口耐压 Output port withstand voltage	Vout		28		V	

电气参数 Electrical parameters ( $T_a = -40 \sim +85^\circ\text{C}$ ,  $V_{ss} = 0\text{V}$ ,  $V_{dd} = 4.5 \sim 5.5\text{V}$ )

参数 parameter	符号 Symbol	最小 minimum	典型 typical	最大 maximum	单位 Unit	测试条件 Test condition
低电平输出电流 Low Level Output Current	Iol	10	-	-	mA	$V_o = 0.4\text{V}$ , DO, PO
高电平输出电流 High level Output Current	Ioh	10	-	-	mA	$V_o = 4\text{V}$ , DO, PO
输入电流 Input current	Ii	-	-	$\pm 1$	$\mu\text{A}$	
差分输入共模电压 Differential input common mode voltage	Vcm			12	V	
差分输入电流 Differential input current	Iab			18	$\mu\text{A}$	VDD=5V
差分输入临限电压 Differential input threshold voltage	Vth	-0.2		0.2	V	$0 < V_{cm} < 12\text{V}$
差分输入迟滞电压 Differential input hysteresis voltage			70		mV	$V_{cm} = 0\text{V}$
差分输入阻抗 differential input impedance	Rin		280		K $\Omega$	A, B port to ground
输出管脚电流 Output pin current	Isink			60	mA	R, G, B, W (REXT to ground resistance 1500 ohm)
高电平输入电压 High level input voltage	Vih	0.7Vdd	-		V	PI

## DMX512 decoding and driving IC

## UCS512A1

低电平输入电压 Low level input voltage	$V_{il}$	-	-	$0.3V_{dd}$	V	PI
电流偏移量 Current offset	$dI_{out}$		$\pm 3.0$	$\pm 5.0$	%	$V_{ds}=1V, I_{out}=17mA$
电压偏移量 Current offset VS-Vds	$\%dV_{ds}$		$\pm 0.1$	$\pm 0.5$	%/V	$1V < V_{ds} < 3V$
电压偏移量 Current offset VS-Vdd	$\%dV_{ds}$		$\pm 1.0$	$\pm 2.0$	%/V	$4.5V < V_{dd} < 5.5V$
动态电流损耗 Dynamic current loss	$I_{DDdyn}$	无负载		4	mA	VDD=5
额定功率 Rated power	PD		400		mW	( $T_a=25^\circ C$ )

开关特性 Switching characteristics ( $T_a = -40 \sim +85^\circ C$ ,  $V_{ss} = 0V$ ,  $V_{dd} = 4.5 \sim 5.5V$ )

参数 parameter	符号 parameter	最小 minimum	典型 typical	最大 maximum	单位 Unit	测试条件 Test condition
传输延迟时间 Transmission delay time	$T_{flz}$	-	-	300	ns	$C_1 = 15pF, D_{IN} \rightarrow D_{OUT}, R_1 = 10k\Omega$
下降时间 Fall time	$T_{thz}$	-	-	120	$\mu s$	$C_1 = 300pF, OUTR/OUTG/OUTB$
数据传输速率 Data transmission rate	F			500	Kbps	
输入电容 Input capacitance	$C_i$	-	-	15	pF	-

## 通信数据协议: Communication data protocol

UCS512A1 数据接收兼容标准DMX512(1990)协议及拓展DMX512协议,数据传输速率250kbps至500K自适应解码。协议波形如下所示: 芯片是AB差分输入的, 下图是A的时序波形, B与A相反。

UCS512A1 data receive compatible standard DMX512 (1990) protocol and extend DMX512 protocol, Data transfer rate 250kbps to 500K adaptive decoding. The protocol waveform is shown below: the chip is AB differential input, The following figure is the timing of the A waveform, B and A on the contrary.

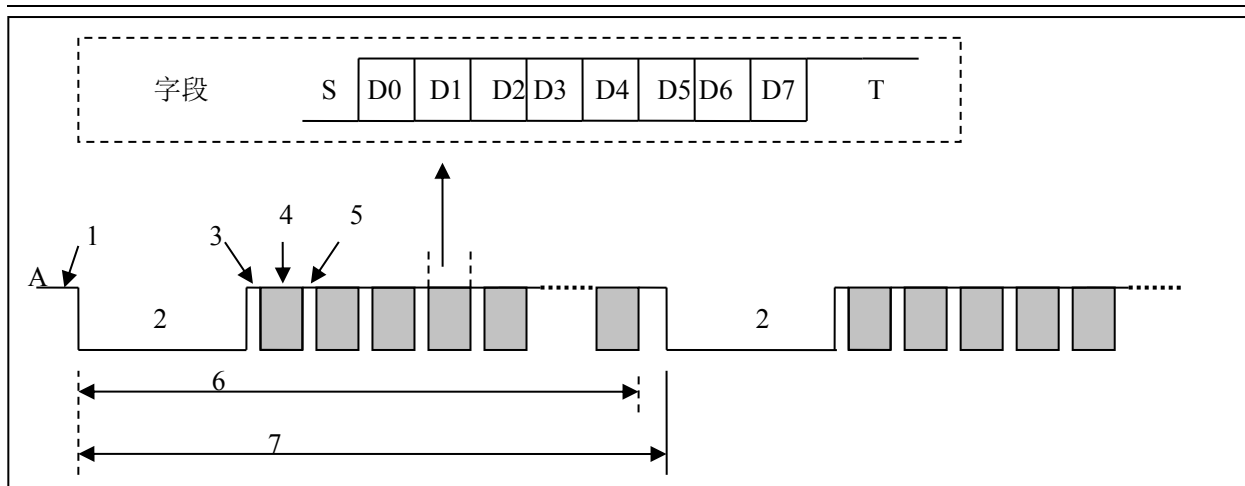

符号 Symbol	描述 describe	最小值 minimum	典型值 Typical	最大值 Maximum	单位 Unit
	比特率 bit rate	200	250	500	Kbps
	位时间 Bit time	5	4	2	us
S	起始位 Starting position	5	4	2	us
D0~D7	数据位 Data bits	5	4	2	us
T	2 位停止位 2 stop bits	10	8	4	us
1	复位前标记 Mark before reset	0		1000000	us
2	复位信号 Reset signal	88		1000000	us
3	复位后标记 Mark after reset	8		1000000	us
4	字段 (note1) field	55	44	22	us
5	字段之间的占 Between fields	0		1000000	us
6	数据包的长度 packet length	1024		1000000	us
7	复位信号间隔 Reset signal interval	4096		1000000	us

**Note1:** 字段共 11 位，包括 0 起始位，8 位数据位和 2 位停止位。其中 0 起始位是低电平，停止位是高电平，数据位中的数据是 0，则相应的时间段是低电平;是 1，则相应的时间段是高电平。0 起始位，停止位及数据位的每一位的时间长度必须相同

Field a total of 11 bits, Including 0 start bit, 8 bit data bit and 2 bit stop. The 0 start bit is low, and the stop bit is high. The data in the data bit is 0, the corresponding time period is a low level; it is 1, the corresponding time period is high. 0 start bit, stop bits and data bits, Each time length must be the same

**接收说明: Receiving instructions**

1. 数据包中的第1字段是起始字段，其8位数据必须是“0000\_0000”，该字段不作为显示数据用。用于显示的有效字段从第二字段开始，512数据包的第二字段是有效数据的第一字段。

The first field in the data package is the initial field, and the 8 bit data must be "0000\_0000", The field is not used as a display data. For an effective field to be displayed from the second field, the second field of the DMX512 data packet is the first field of the valid data.

2. IC 根据其 E2 中地址确定截取 512 数据包中对应的字段。如芯片地址为 0000\_0000\_0000 则从数据包的第一有效字段开始截取，地址 0000\_0000\_0001 从第二有效字段开始截取。当芯片截取完自身需要的字段后，还要继续截取并转发 192 个字段。转发信号完全兼容我公司 19 和 29 系列 IC。芯片自身使用多少字段，由 PT1 和 PT0 设置。

IC based on its E2 address to determine the interception of the 512 packets in the corresponding field, If the chip address is 0000\_0000\_0000, the first effective field from the data packet begins to intercept. If the chip address is 0000\_0000\_0001, the second effective field from the data packet begins to intercept. When the chip after the interception of their own needs of the field, but also continue to intercept and forward 192 fields, The forward signal is fully compatible with our company's 29 series IC. How many fields are used by the chip itself, by the PT1 and PT0 settings.

PT1 (Built in pull down)	PT0 (Built in pull down)	
0	0	3 字段模式: 截取 3 字段, 分别对应 R, G, B, 其余转发 3 field mode: the interception of 3 fields, respectively, corresponding to R, G, B. Other forwarding
0	1	4 字段模式: 截取 4 字段, 分别对应 R, G, B, W 4 field mode: the interception of 4 fields, respectively, corresponding to R, G, B, W. Other forwarding
1	0	2 字段模式: 截取 2 字段, 分别对应 RG, BW 2 field mode: the interception of 2 fields, respectively, corresponding to BW, RG. Other forwarding
1	1	1 字段模式: 截取 1 字段, 对应 RGBW 1 field mode: the interception of 1 fields, corresponding to R, G, B, W. Other forwarding

上表中1字段模式和2字段模式可以实现扩大电流的功能,如1字段模式中(一般为单色应用),可将RGBW 4个输出管脚连接在一起使用,这时最大输出电流可达240mA。1字段模式及2字段模式使用在数据转发及扩大电流情况下,当不需要扩大电流并且不需要转发控制29系列IC时,不论单色,双色还是RGB三色都可以选择3字段模式即可(4色应用时应选用4字段模式)。

On the table 1 field mode and 2 field mode can achieve the function of expanding the current, Such as the 1 field mode (usually for monochrome applications), RGBW 4 output pins can be connected together to use, maximum output current up to 240mA. 1 field mode and 2 field modes are used in the data forwarding and extended current, when do not need to expand the current and does not require forwarding and control 29 series IC, Regardless of monochrome, dual color or RGB three color are selected 3 field mode can be (4 color application should use the 4 field



mode).

4. IC 接收数据时，2 个复位信号间隔不能小于 4mS。也就是说，即使并行联结负载极少的情况下，帧频也不能大于 250HZ

data is received, the two reset signal intervals not less than 4mS. That is to say, the frame rate is not greater than 250HZ

#### 写码注意事项: Note to write code:

- 1 写码前，应将控制器的 A, B, PO, GND 4 个口用铜线牢固连接到灯具上并仔细检查。注意，写码时 AB 线也须接在控制器的 A, B 口上，控制器的 A, B 口在写码时保持 A 高 B 低的电平，IC 须在 A 高 B 低的状态下方能正常写码。此为 IC 防误码专用功能之一。

Before writing the code, should be the controller of the B, A, PO, GND 4 mouth with copper wire firmly connected to the lamp and carefully check. Note, when write code, the lamp AB line must be connected to the controller's A, B port, the controller's A, B port in the write code to keep the A high B low level, IC must be in the state of A high B low can write code. This is one of the IC anti error function.

2. 写码前，控制器先使用 R, G, B 整体同步跳变程序测试，以确认 A, B 线是否存在问题，若此程序不正常，不要进行写码操作，先排查此问题后再写码。

Before writing code, the controller first uses R, G, B, the whole synchronous jump program test

3. 写码完成后，收到新地址码的 IC 驱动蓝灯常亮，此时新地址码已生效。

After the completion of the write code, the IC of received new address code to driver blue light bright, this time the new address code has come into effect.

#### 其它注意事项: Other matters needing attention:

1. 在不连接控制器的情况下上电，悬空的 AB 总线可能会受到电磁干扰而产生干扰电平，

UCS512A1 接收到干扰电平，其 RGBW 通道可能会根据干扰电平产生相应显示。如果希望悬空的 AB 总线保持稳定的显示状态，建议在 A 端口对 VDD 端口间连接一个 1M 欧姆的电阻(A 端口接上拉电阻使 AB 线悬空时状态稳定，但也会影响 AB 线的平衡，造成可并行联接负载数量的下降及缩短可允许的 AB 总线长度，所以要使用更小的上拉电阻时应谨慎)

In the case of the controller is not connected, The suspended AB bus may be interfered by electromagnetic interference. If UCS512A1 received interference level, the RGBW channel will generate the corresponding display according to the interference level. If you wish to remain in a stable state of the suspended AB bus, Between the A port to the VDD port to connect a 1M ohm pull up resistance (The A port is connected with the pull up resistor to stabilize the suspended AB bus, but it can also affect the balance of the AB line, which can cause the decrease of the number of parallel connection loads and shorten the length of the AB bus., So be careful when using smaller pull up resistance)

#### 输出恒流设置: Output constant current setting:

R, G, B, W 是恒流输出，最大可达 60mA，不建议将电流设置为更大值应用。REXT 端口对地连接的电阻阻值设定恒流电流值。电流公式：

R, G, B, W is the constant current output, the maximum can reach 60mA, it is not recommended to set the current to a larger value of the application. The REXT port resistance value connected to ground set constant current value



Current formula:

$$I=48/(400+R_{ext}) \quad (1)$$

$$R_{ext}=(48/I)-400 \quad (2)$$

$R_{ext}$  是跨接在 REXT 脚和地之间的电阻,  $I$  是 R, G, B, W 端口输出的电流。

$R_{ext}$  is connected across the resistance between the REXT port pin and ground port, the  $I$  is the R, G, B, W port output current.

例如: 想得到 17mA 的电流, 使用 (2) 式,  $R_{ext}=(48/0.017)-400$ , 最终得到  $R_{ext}=2423$  欧姆。

想得到 34mA 的电流, 使用 (2) 式,  $R_{ext}=(48/0.034)-400$ , 最终得到  $R_{ext}=1011$  欧姆。

For example: would like to get the 17mA of the current, using (2) type,  $R_{ext}=(48/0.017)-400=2423$  ohm.

would like to get the 34mA of the current, using (2) type,  $R_{ext}=(48/0.034)-400=1011$  ohm.

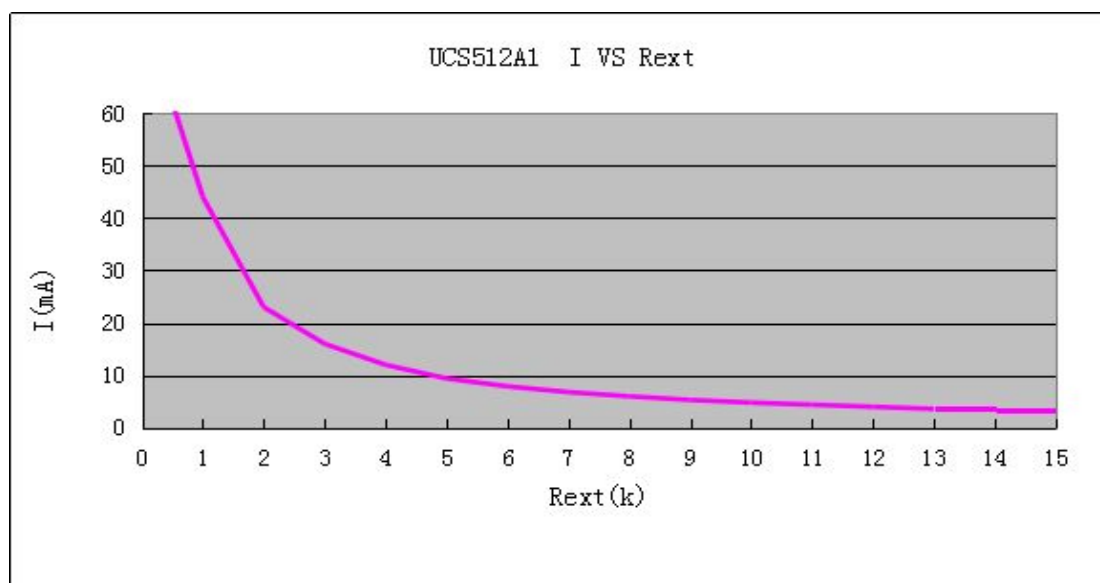

#### 恒流曲线: Constant current curve:

UCS512A1 恒流特性优异, 通道间甚至芯片间的电流差异极小。

(1): 通道间的电流误差小于  $\pm 1.5\%$ , 而芯片间的电流误差小于  $\pm 3\%$ 。

(2): 当负载端电压发生变化时, UCS512A1 输出电流不受影响, 如下图所示

(3): 如下图 UCS512A1 输出端口的电流  $I$  与加在端口上的电压  $V_{ds}$  曲线关系可知,  $I$  电流越小, 在恒流状态下, 需要的  $V_{ds}$  也越小。

The UCS512A1 constant current characteristic is excellent, and the current difference between the channels and even the chip is very small.

(1): While the current error between the chip is less than 3 percent

(2): When the load side voltage changes, the UCS512A1 output current is not affected, as shown below

(3): As shown below the UCS512A1 output port of the current  $I$  and the voltage on the port  $V_{ds}$  curve relationship shows that the smaller the current  $I$ , In the constant current state, the need of the  $V_{ds}$  is also smaller.

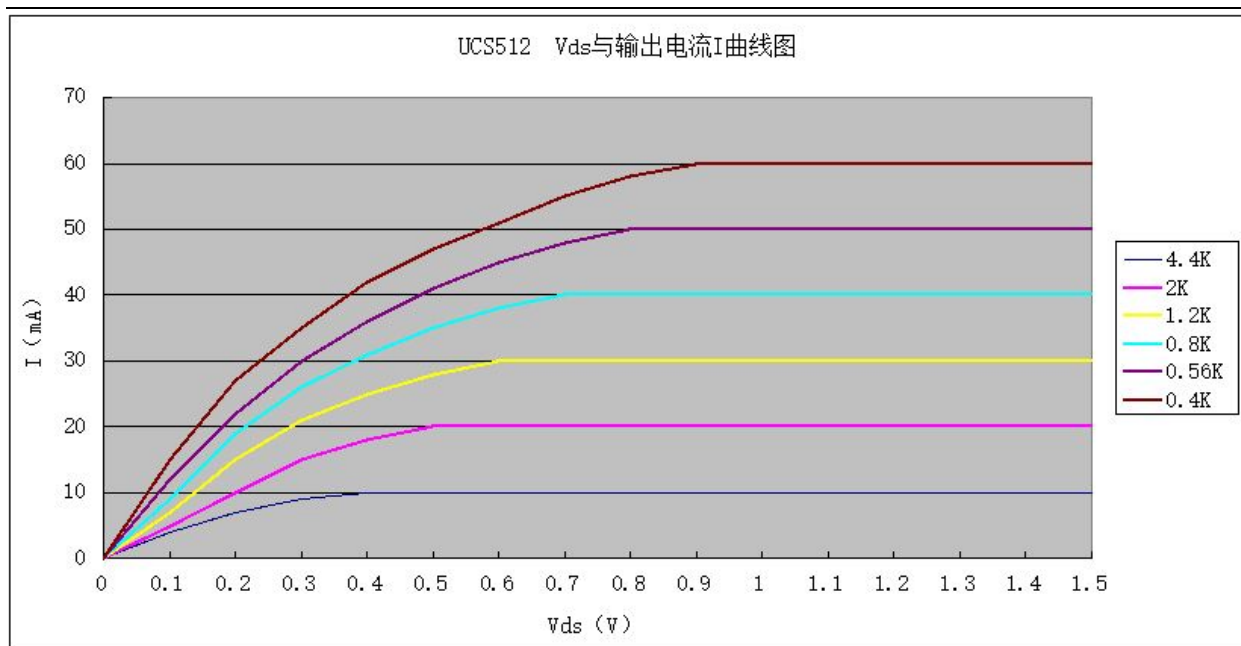

### 分压电阻: Voltage dividing resistance

UCS51A1 为 SOP16 封装, 长时间工作时 IC 上的功耗一般不能超过 400mW, 以 3 通道输出每通道恒流 20mA 为例, 如果 IC 的每个输出管脚电压 (V<sub>ds</sub>) 为 5V, 则 IC 上功耗为:

UCS51A1 for the SOP16 package, a long time to work on the IC power consumption is generally not more than 400mW, 3 channel output per channel constant current 20mA, for example, If the IC of each output pin voltage (V<sub>ds</sub>) is 5V, then the IC power consumption is:

$$P = P_{RGB} + P_{VDD} = 3 * 5V * 20mA + 5V * 10mA = 0.3 + 0.05 = 0.35W$$

分压电阻最小值: 例如, 24V 供电, RGB 输出, 各 6 串, 恒流值设定 20mA, V<sub>ds</sub> 取 5V

Minimum value of Voltage sharing resistance: For example, 24V power supply, RGB output, each 6 strings, Constant current setting 20mA, V<sub>ds</sub> take 5V

红灯 red light  $R > (24V - 6 * VR - 5V) / 20mA = (24V - 6 * 2 - 5V) / 20mA = 350$

绿, 蓝灯 Green, blue light  $R > (24V - 6 * VR - 5V) / 20mA = (24V - 6 * 3V - 5V) / 20mA = 50$

为防止 IC 超过最大功耗, 在下表列出了不同 RGBW 通道电流大小情况下 V<sub>ds</sub> 的参考最大值, 实际应用中, 先选定 V<sub>ds</sub> 取值, 再计算分压电阻阻值。

In order to prevent the IC from exceeding the maximum power consumption, In the following table lists the maximum reference values for the V<sub>ds</sub> with different RGBW channel current sizes, Practical application, the first selected V<sub>ds</sub> value, and then calculate the value of Voltage sharing resistance

V <sub>ds</sub> (V)	3 channel output (mA)			4 channel output (mA)		
	20	40	60	20	40	60
	5	2.5	1.7	4	2	1.3

## 工程连接示意图 Engineering connection sketch map

## 1. 250K 标准 DMX512 发送频率 250K standard DMX512 transmission frequency

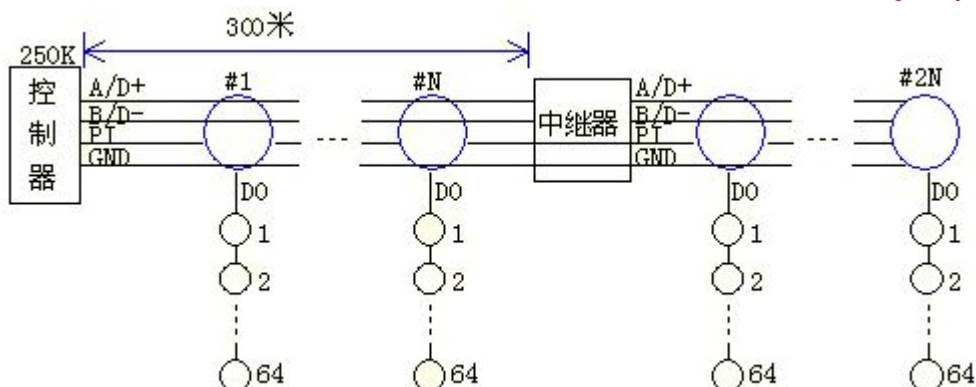

当控制器发送速率为 250K 时，可在不加中继器和终端匹配电阻的情况下连接 300 米的 AB 总线，线上最多可挂 1024 个负载（ $N=1024$ ），须注意帧频限制。如果需要更长的总线，可如图使用差分中继器

When the controller sends a rate of 250K, The 300 meter AB bus can be connected in the case of no repeater and terminal matching resistance, and can hang up to 1024 loads on the AB bus ( $N=1024$ ), pay attention to the frame rate limit. If you need longer bus, you can use the differential repeater

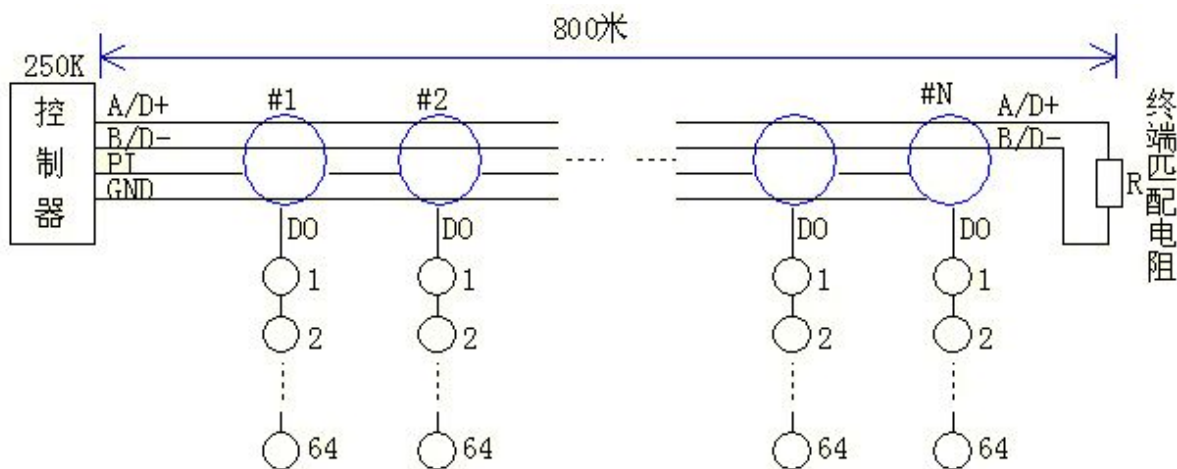

当控制器发送速率为 250K 时，可在不加中继器情况下使用终端匹配电阻，连接不超过 800 米的 AB 总线，线上最多可挂 1024 个负载（ $N=1024$ ），须注意实际帧频限制。

When the controller sends a rate of 250K, it can use the terminal matching resistor in the case of no repeater, the connection is not more than 800 meters of the AB bus, and can hang up to 1024 loads on the AB bus ( $N=1024$ ), pay attention to the frame rate limit.

## 2. 500K 标准 DMX512 发送频率 500K standard DMX512 transmission frequency

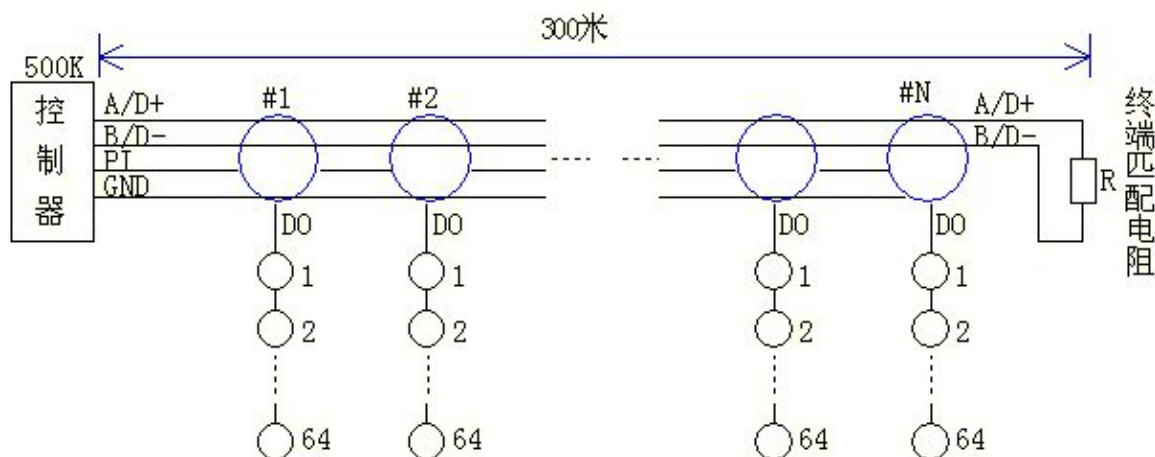

当控制器发送速率为 500K 时，在不加中继器情况下应使用终端匹配电阻，连接不超过 300 米的 AB 总线，线上最多可挂 1024 个负载 (N=1024)，须注意实际帧频限制。如果需要更长的 AB 总线，可使用差分中继器。如果在 500K 速率下未加终端匹配电阻，也没加中继器，AB 总线应不超过 60 米

When the controller sends a rate of 500K, it can use the terminal matching resistor in the case of no repeater, the connection is not more than 300 meters of the AB bus, and can hang up to 1024 loads on the AB bus (N=1024), pay attention to the frame rate limit. If need longer AB bus, you can use the differential repeater. If the 500K rate does not add a terminal matching resistor, also did not add a repeater, AB bus should not exceed 60 meters

注：

1. 以上的数据是使用普通护套线 (0.3mm) 或排线测试得出。用双绞线可提高抗干扰能力及总线长度。干扰较多情况下，建议使用 5 类或超 5 类网线，强干扰或多雷电的地区应采用屏蔽双绞线。
2. 以上数据是使用手牵手总线拓扑结构测试得出，如使用星型或树形总线拓扑结构，总线长度将相应缩短，这种情况下应尽量减少分支线长度以减少反射信号的影响，如果反射信号过大造成显示异常，可使用差分中继器
3. 图中 DO 连接的 64 点是 IC 转发控制 29 系列 IC 时最多可控制 64 个 RGB 点 (192 个通道)，这 64 个点为串联总线结构 (归 0 码协议)

Notes:

1. The above data is the use of ordinary cable (0.3mm) test, Using twisted pair lines to improve the ability of anti-interference and AB bus length. Interference more cases, it is recommended to use 5 or 5 types of network cable, strong interference or multi lightning area should be shielded twisted pair.
2. The above data is obtained by using the hand-in-hand bus topology test, If the Star or tree bus topology is used, the bus length will be Corresponding shortening, In this case, the length of branch line should be reduced to reduce the influence of the reflection signal, If the reflected signal is too large

to display an exception, differential repeater can be used

- In Figure , DO port connect 64 point , it is the UCS512A1 forwarding control 29 series IC, it can control up to 64 RGB points (192 channels)。The 64 point is the serial bus architecture (regression 0 code Protocol).

应用图 1: R, G, B, W, 4 字段应用 Application chart 1: R, G, B, W, 4 field mode application

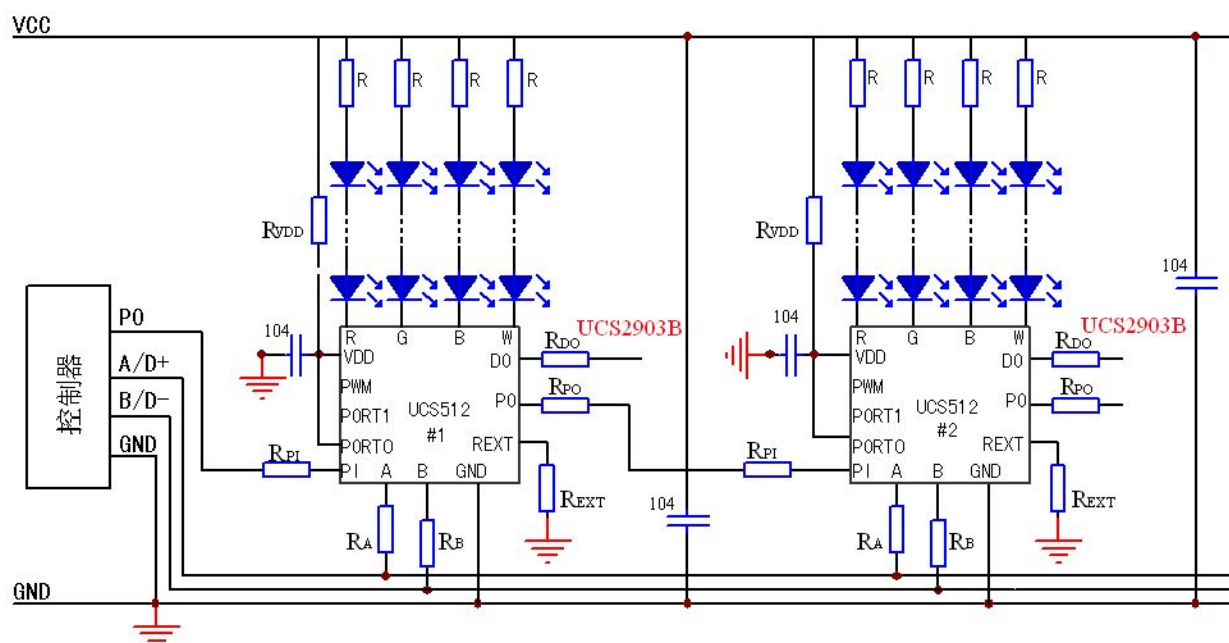

- 注: 1. 根据拓展需要, DO 端口可连接 UCS29 系列 IC, 如 2903B, 2904B, 2909B, 2912B 等  
According to the expand needs, DO port can be connected to the UCS29 series , such as 2903B, 2904B, 2909B, 2912B, etc.
2. REXT 端口必须连接电阻到地来设置输出电流 (在反极性应用情况下, 此端口可以悬空)  
REXT port must be connected to the ground to set the output current (in the case of reverse polarity applications, this port can be suspended)
3. 4 字段模式下, 4 个字段分别对应 RGBW 4 端口, PORT0 连接 VDD, PORT1 悬空  
4 field mode. 4 fields correspond to R, G, B, W 4 ports., PORT0 connection VDD , PORT1 suspended

应用图 2: R, G, B 3 字段应用 Application chart2: R, G, B 3 field mode application

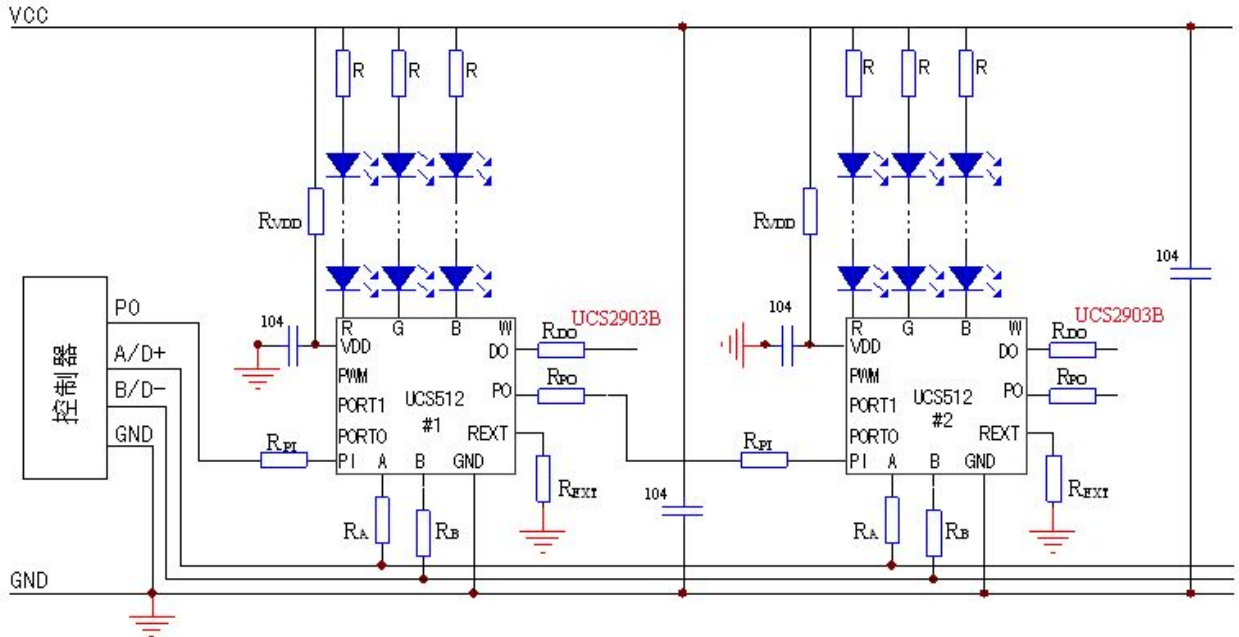

- 注: 1. 根据拓展需要, DO 端口可连接 UCS29 系列 IC, 如 2903B, 2904B, 2909B, 2912B 等  
According to the expand needs, DO port can be connected to the UCS29 series, such as 2903B, 2904B, 2909B, 2912B, etc.
2. REXT 端口必须连接电阻到地来设置输出电流 (在反极性应用情况下, 此端口可以悬空)  
REXT port must be connected to the ground to set the output current (in the case of reverse polarity applications, this port can be suspended)
3. 3 字段模式, 3 个字段分别对应 R, G, B 3 个端口, PORT0 悬空, PORT1 悬空  
3 field mode, 3 fields correspond to R, G, B 3 ports, PORT0 suspended, PORT1 suspended

应用图 3: RG, BW 2 字段应用 Application Figure 3: RG, BW 2 field mode application

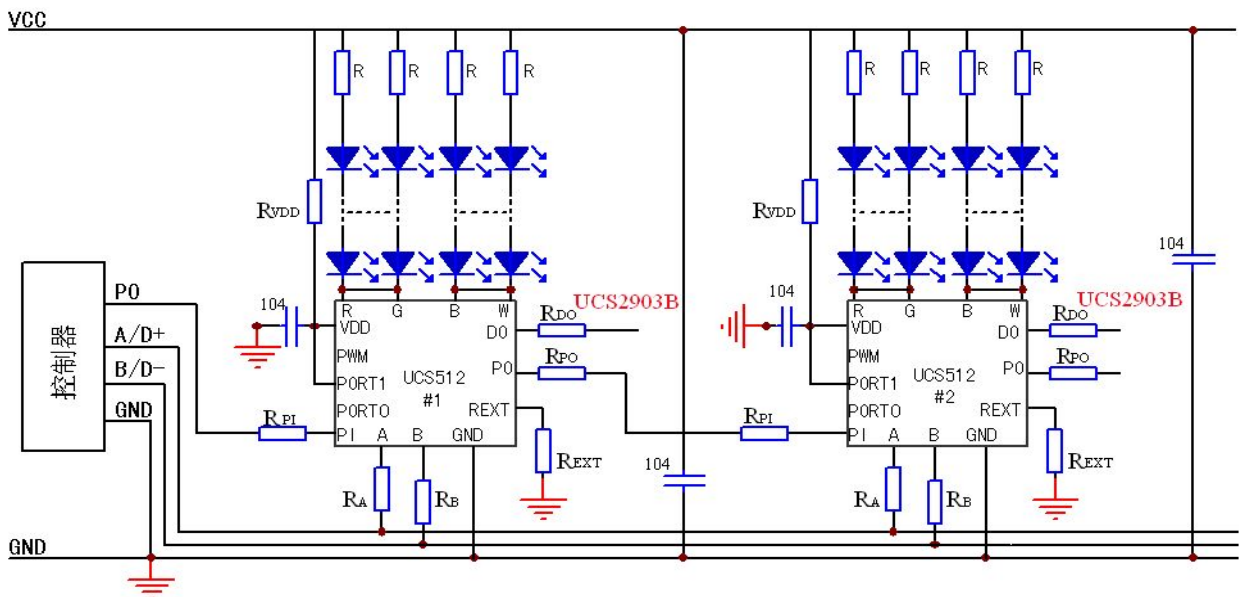









output, RGBW port can be connected to the NPN transistor or MOS tube. For such applications, the RGBW port should be connected to the pull up resistor to VDD port. As shown in the figure, the pull up resistor R1 should be selected according to the actual current size and the transistor amplification factor. Reference component selection table B: (Application of transistor)

2. 上图为 4 通道反极性应用时的应用图。其它字段反极性应用时注意 PORT0 及 PORT1 口选择  
Application diagram for reverse polarity applications of 4 channels. Attention to PORT0 and PORT1 port selection when other applications of reverse polarity applications

4. 在反极性应用下，REXT 端口可以悬空  
In reverse polarity applications, REXT port can be suspended

In reverse polarity applications, REXT port can be suspended

应用图 6: 外接开关式恒流驱动 IC (例: UCS2915), 其它开关式恒流驱动 IC 使用方式类似)

Application of figure 6: external switch constant current drive IC (example: UCS2915), Other switch constant current drive IC use similar

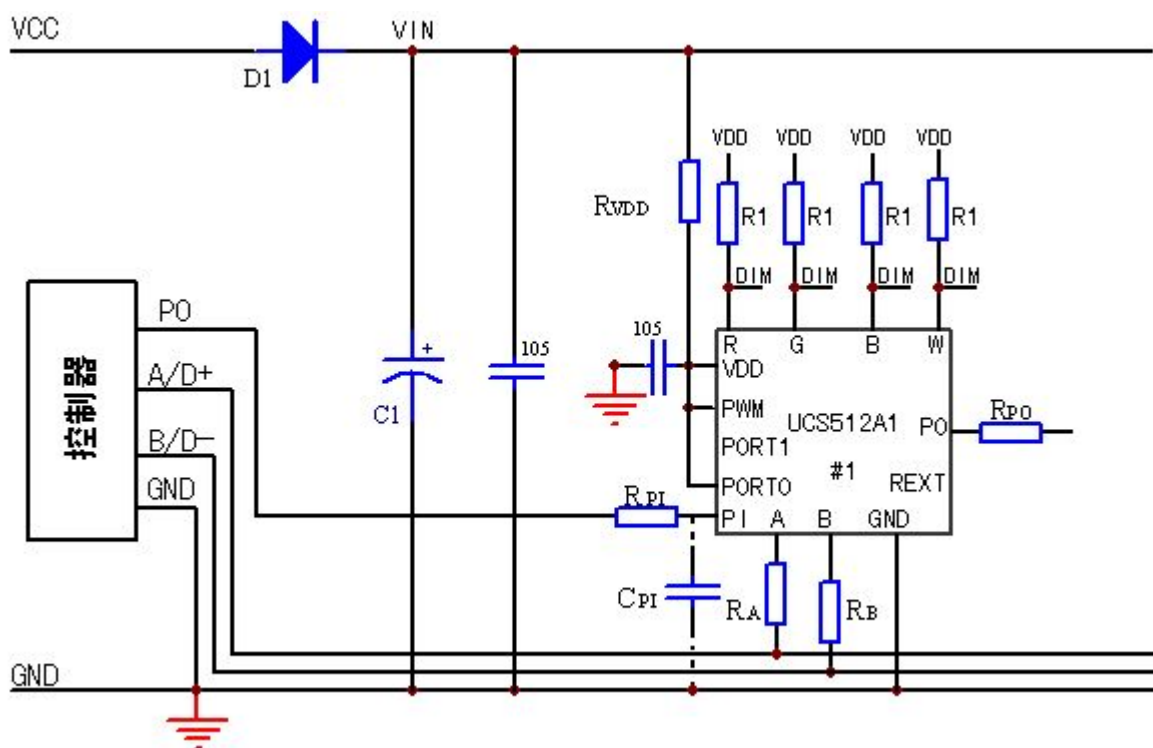

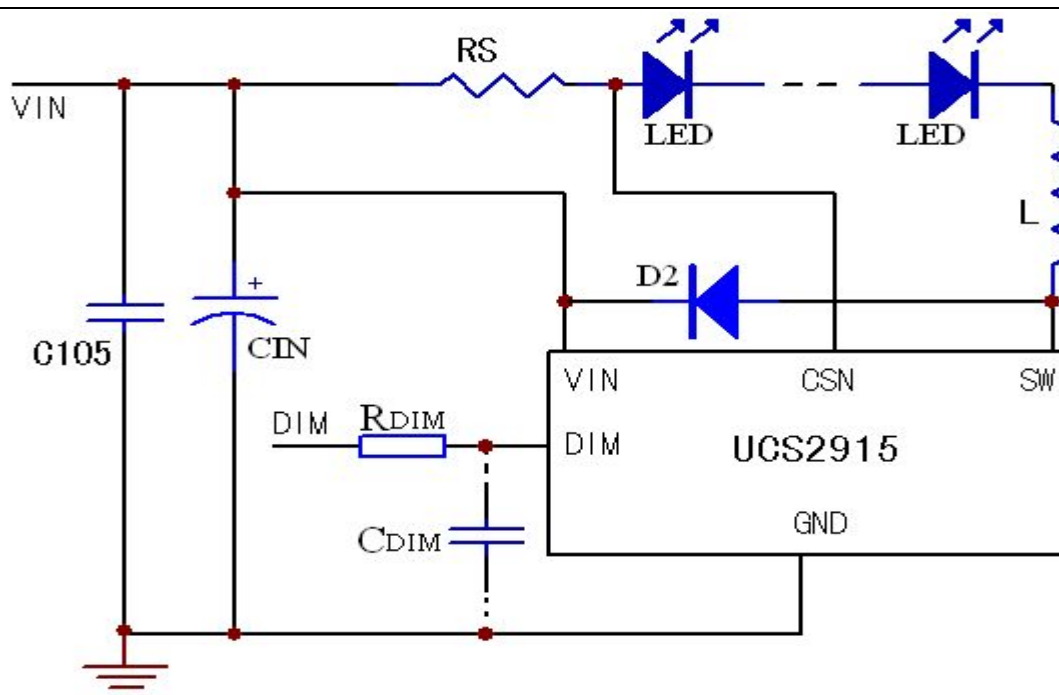

注：1. PWM 管脚接 VDD 时，为反极性非恒流输出，可外接大功率恒流驱动 IC，此类应用时，RGBW 通道应连接上拉电阻到 VDD，如图所示，上拉电阻 R1 取值 10K 以上

When the VDD pin is connected to the PWM port, it is the reverse polarity non constant current output, RGBW port can be connected to High power constant current driver IC. For such applications, the RGBW channel should be connected to the pull up resistor R1 to VDD port, As shown in Figure. Up pull resistor R1 value above 10K

2. 上图为 4 字段反极性应用时的应用图。其它字段反极性应用时注意 PORT0 及 PORT1 口选择  
Application diagram of 4 field reverse polarity applications. Attention to PORT0 and PORT1 port selection when other applications of reverse polarity applications

3. 在反极性应用下，REXT 端口可以悬空  
In reverse polarity applications, REXT port can be suspended

4. 当采用开关式恒流驱动 IC 时,系统会产生较大的噪声及浪涌干扰，严重情况会造成无法写码或画面变化不正常，注意以下措施：

When the switch type constant current drive IC, the system will have a greater noise and surge interference. Serious situation can cause the code can not be written or screen change is not normal. Pay attention to the following measures:

A: 注意电感 L 的位置应该在 LED 及 IC 的 SW 脚之间，不要将 LED 和电感 L 调换位置，否则会加大干扰情况。

Note that the position of the inductor L should be between LED and UCS2915 SW feet., Do not Swap position the LED and the inductance L. Otherwise would Increase the interference situation.

B: 所有的 UCS2915 VIN 脚和 UCS512 降压电阻 RVDD 须直接相连，接在同一个防止反向连接的二极管后面，以降低浪涌影响，不能出现 UCS2915 VIN 脚和 UCS512 的降压电阻 RVDD 连接在不同的防反接的二极管后面。

All of the UCS2915 VIN pin and UCS512 step down resistor RVDD shall be connected directly to the back of the diode D1, In order to reduce the impact of surge. Can not appear on the UCS2915 VIN

and UCS512 step down resistance RVDD connection Behind the different diodes.

- C: 线路板上 UCS2915 的 VIN 脚到 UCS512 降压电阻 RVDD 的走线尽量粗而短（尽可能接近等电位），UCS2915 的 GND 脚和 UCS512 的 GND 脚之间的走线尽量粗而短（尽可能接近等电位）  
UCS2915 VIN port on the circuit board to the UCS512 step down resistance RVDD the line as far as possible the thick and short, UCS2915 GND port on the circuit board to the UCS512 GND port the line as far as possible the thick and short
- D: 在每个 UCS2915 靠近 VIN 和 GND 脚处连接一个 47uF 的电解电容（如图 CIN）和 105 的电容，在靠近 UCS512A1 的降压电阻 RVDD 和 GND 脚处连接一个 47uF 的电解电容（如图 C1）和 105 的电容。  
At each UCS2915 near the VIN and GND pins connect a 47uF of electrolytic capacitors (Figure CIN) and 105 of the capacito。 UCS512A1 step down resistance RVDD and GND pins connect a 47uF of electrolytic capacitors (Figure C1) and 105 of the capacito
- E: AB 线在板上应始终保持并行布线，非实在无法过线这种特殊情况下尽可能不要在 AB 线间插入其它元件或布线（即使在特殊情况下也要限制在最短的局部）。否则 AB 线平衡传输的抗干扰功能会被减弱  
AB lines on the board should always keep the parallel wiring, As far as possible not to insert other element or wiring between the AB line Part
- F: 当干扰过大造成无法完成写码的情况发生时，可如图在 IC 的 PI 对 GND 加一个电容 RPI 的滤波电容以滤除一定程度干扰，电容大小可根据情况选择，加入 CRPI 电容也会造成实际写码信号的衰减（电容越大，抗干扰作用越强，但信号衰减也越大），减少能写码成功的数量。例如，Cpi=102PF，这种情况下建议控制器每端口能连接的 UCS512A1 数量不超过 250 个）。  
When the interference is too large to can not write code , as the figure in the PI port to the GND port plus a capacitor Cpi to filter a certain degree of interference。Capacitor size can be selected according to the situation。Cpi capacitance also causes the actual write code signal attenuation (The bigger the capacitance, the stronger the anti-interference effect, but the bigger the signal attenuation.) , reduce the number of successful write code。for example, Cpi=1000PF, In this case, it is recommended that the number of UCS512A1 connected to each controller port is not more than 250
- G: 在特殊情况下，因为 DIM 脚被干扰，造成显示不正常现象，此时需如图在 UCS2915 的 DIM 脚对 GND 加一电容 CDIM，电容大小根据实际情况确定，一般在几十至 100PF。  
Under special circumstances, because the DIM port is disturbed, Cause the display is not normal, as the figure, in the DIM port to the GND port plus a capacitor CDIM to filter a certain degree of interference, CDIM size according to the the actual situation, the general in the dozens to 100PF.

元器件选值表 A: (非三极管应用) Component selection table A: (Application of non transistor)

元件 element	24V supply voltage	12V supply voltage	5V supply voltage
RVDD	2K-2.2K Ω	750-820 Ω	75-100 Ω
RPI	300-400 Ω	300-400 Ω	
RPO	300-400 Ω	300-400 Ω	
RA	5K-10K Ω	5K-10K Ω	5K-10k Ω
RB	5K-10K Ω	5K-10K Ω	5K-10k Ω
RDO	120-150 Ω	120-150 Ω	无

元器件选值表 B: (三极管应用, 单路电流不超过 120mA)

Component selection table B: (Application of the transistor, single current is not more than 120mA)

元件 element	DC24V supply voltage	DC12V supply voltage
R1	2.5K $\Omega$	2.5K $\Omega$
RVDD	1K $\Omega$	300 $\Omega$

VDD 和 GND 端口并行连接一个 5V 稳压管  
 The VDD and GND ports are connected in parallel to a 5V regulated tube

注: 更大的电流应用建议使用 MOS 管, 使用 MOS 管时 R1 取值 10K 以上

Note: the greater the current application is recommended to use the MOS tube, the R1 value is above 10K

封装外形图和尺寸 Package outline diagram and dimensions

SOP16

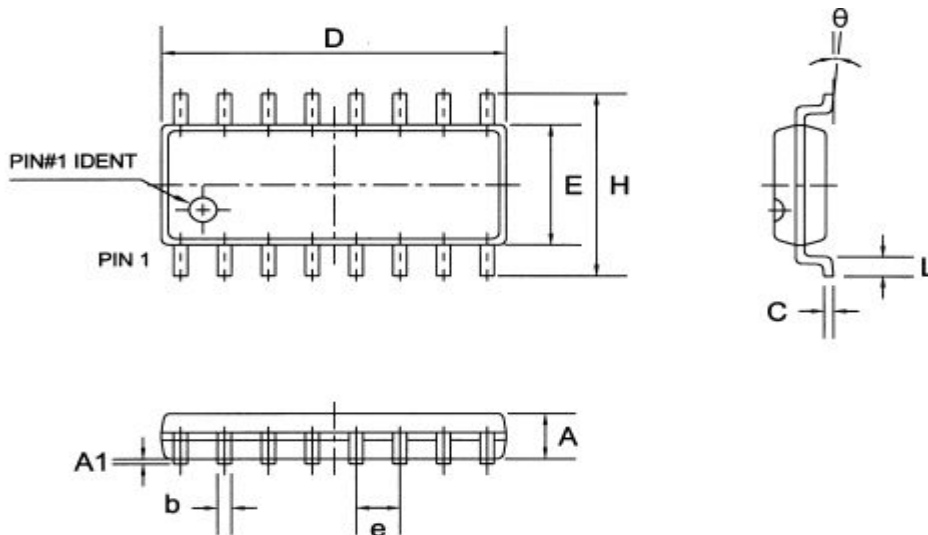

Symbol	Dimensions In Millimeters			Dimensions In Inches		
	Min	Nom	Max	Min	Nom	Max
A	1.30	1.50	1.70	0.051	0.059	0.067
A1	0.06	0.16	0.26	0.002	0.006	0.010
b	0.30	0.40	0.55	0.012	0.016	0.022
C	0.15	0.25	0.35	0.006	0.010	0.014
D	9.70	10.00	10.30	0.382	0.394	0.406
E	3.75	3.95	4.15	0.148	0.156	0.163
e	—	1.27	—	—	0.050	—
H	5.70	6.00	6.30	0.224	0.236	0.248
L	0.45	0.65	0.85	0.018	0.026	0.033
theta	0°	—	8°	0°	—	8°

SSOP16L

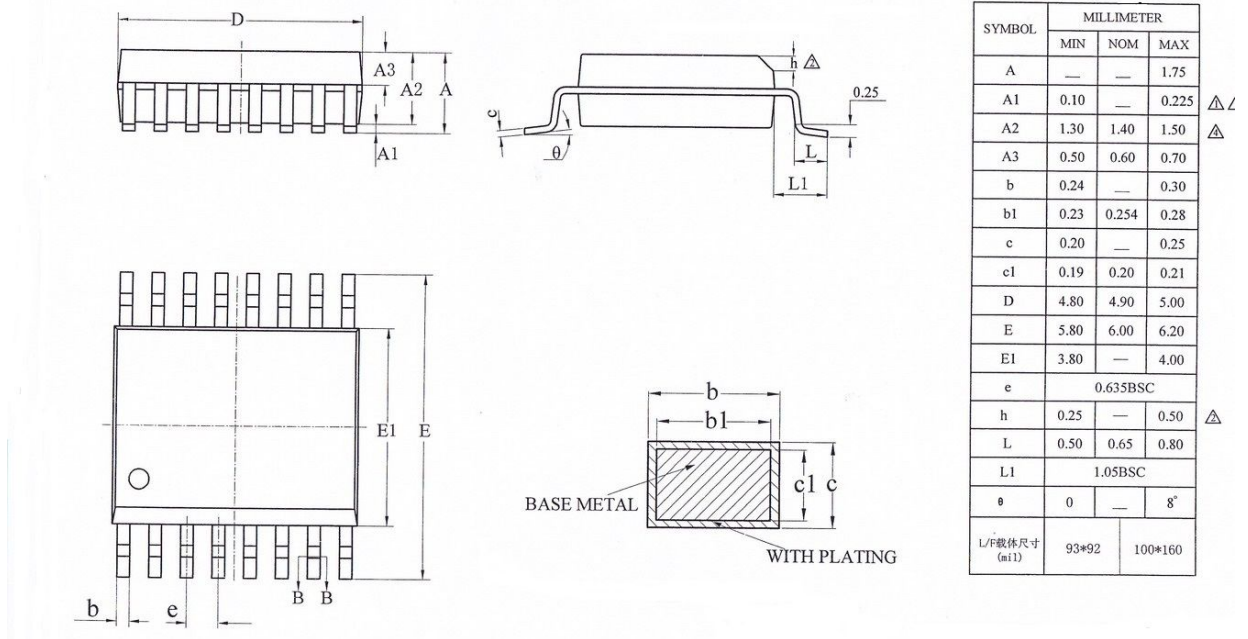

版本 version

版本号 version number	发行日期 Issue date	修订简介 Revised profile
VER1.0	2013-5-25	初版发行 The first edition
VER1.1	2014-5-12	内容修订 Content revision
VER1.2	2014-10-11	性能升级 Performance upgrade
VER1.5	2015-5-14	英文版本 english version