

## Overview

TM1903 is a 3-channel LED fixed constant current drive IC. The chip integrates with MCU solidification program and such circuits as single-wire digital interface, data latch and LED constant current drive. VDD pin integrates with 5V voltage-regulator tube, with few peripheral devices. The product applies to guardrail tube, point light source and other LED decoration products. It boasts excellent performance and reliable quality.

## Features

- Low power consumption CMOS workmanship
- OUT output port withstand voltage 24V
- VDD has built-in 5V voltage-regulator tube, supporting 6-24V voltage after connected in series with resistors
- 14mA fixed constant current output
- PWM luminance control circuit, 256-level luminance control
- Accurate current output value  
Maximum error (between channels):  $\pm 3\%$   
Maximum error (between chips):  $\pm 5\%$
- Single-wire serial concatenated interface
- Oscillation mode: built-in RC oscillation, clock synchronization according to the signals on the data line, automatically regenerate the subsequent data after receiving the data of the current unit and send it to the next level through the data output end, the signals do not distort or attenuate with the distance prolonging of cascade connection
- Built-in power-on reset circuit, all registers are zero-initialized after power-on reset
- Data transmission rate in external control mode: 800KHz
- Packaging mode: SOP8

## Block diagram for internal structure

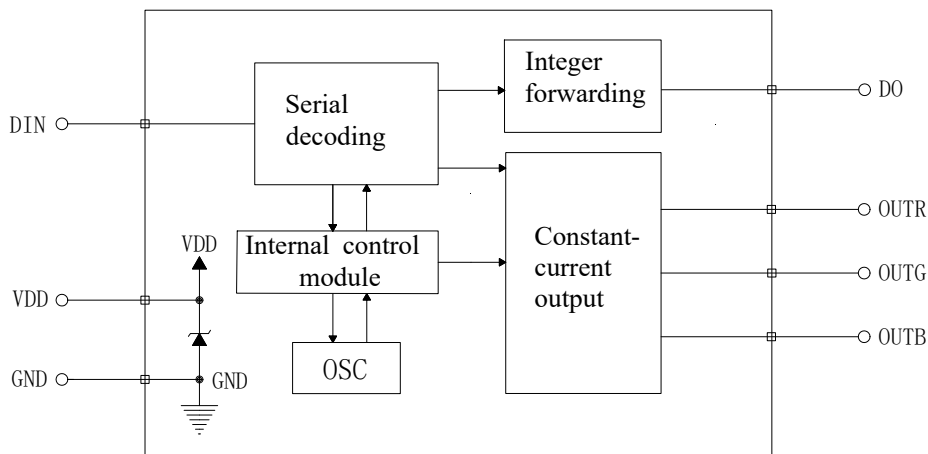

Figure 1

## Pin configuration

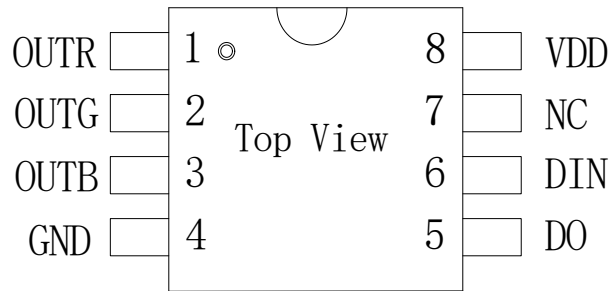

Figure 2

**Pin function**

Pin name	Pin number	I/O	Function description
DIN	6	I	Data input
DO	5	O	Data output
NC	7	--	No pin and electrical connection
OUTR	1	O	N tube open-drain, constant-current output
OUTG	2	O	N tube open-drain, constant-current output
OUTB	3	O	N tube open-drain, constant-current output
VDD	8	--	Positive pole of power supply
GND	4	--	Power ground

**Input/output equivalent circuit**

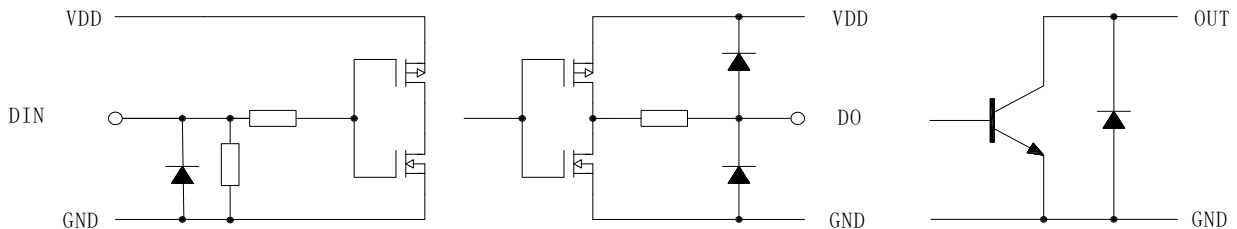

Figure 3



Integrated circuit is an electrostatic sensitive device which tends to generate a lot of static electricity when used in a dry season or dry environment. Electrostatic discharge may damage integrated circuit. Titan Micro Electronics suggests taking all appropriate preventive measures for integrated circuit. Improper operation and welding might cause ESD damage or performance reduction and chip operation failure.

### Limit parameters

Parameter name	Parameter symbol	Limit value	Unit
Logic supply voltage	VDD	-0.4~+7.0	V
DIN port voltage	Vin	-0.4~VDD+0.7	V
OUT port voltage	Vout	-0.4~+30.0	V
Operating temperate range	Topr	-40~+85	°C
Storage temperature range	Tstg	-50~+150	°C
ESD	Human body model (HBM)	3000	V

(1) When the chip works for a long time under the above limit parameters, it may cause device reliability reduction or permanent damage. We do not suggest the chip works by exceeding these limit parameters under any other conditions.

(2) All voltage values are comparatively tested in a systematic way.

### Recommended operating conditions

Tested under -45°C-+85°C, unless otherwise specified			TM1903			Unit
Parameter name	Parameter symbol	Testing condition	Min. value	Typical value	Max. value	
Supply voltage	VDD		4.5	5.0	6.5	V
DIN port voltage	Vin	VDD = 5V, DIN is connected in series with a 1KΩ resistor			VDD+0.4	V
DO port voltage	Vdo	VDD = 5V, DO is connected in series with a 1KΩ resistor			VDD+0.4	V
OUT port voltage	Vout	OUT=OFF			24.0	V

### Electrical characteristics

Tested under VDD = 3.0-5.5V and operating temperature = -40°C-+85°C, unless otherwise specified			TM1903			Unit
Parameter name	Parameter symbol	Testing condition	Min. value	Typical value	Max. value	
High level output voltage	Voh	Ioh=3mA	VDD-0.5			V
Low level output voltage	Vol	Iol=10mA			0.4	V
High level input voltage	Vih	VDD=5.0V	3.5		VDD	V
Low level input voltage	Vil	VDD=5.0V	0		1.5	V
High level output current	Ioh	VDD=5.0V, Vdo=4.9V		1		mA
Low level output current	Iol	VDD=5.0V, Vdo=0.4V		10		mA
Quiescent current	IDD	VDD=4.0V, GND=0V, other ports are suspended	0.5	1.2	1.5	mA
OUT output constant current	Iout	OUTR, OUTG, OUTB=ON, Vout=3.0V	13.3	14	14.7	mA
OUT output leakage current	Iolk	OUTR, OUTG, OUTB=OFF, Vout=24.0V			0.5	μA
Constant-current error between channels	ΔIolc0	OUTR, OUTG, OUTB=ON, Vout=3.0V			±3	%
Constant-current error between chips	ΔIolc1	OUTR, OUTG, OUTB=ON, Vout=3.0V			±5	%
Consumed power	Pd	Ta=25°C			250	mW

**Switch characteristics**

Tested under VDD = 3.0-5.5V and operating temperature = -40°C-+85°C, typical value VDD = 5.0V, TA = +25°C, unless otherwise specified			TM1903			Unit
Parameter name	Parameter symbol	Testing condition	Min. value	Typical value	Max. value	
Data rate	Fin			800		KHz
OUT PWM output frequency	Fout	OUTR, OUTG, OUTB		666		Hz
Time for switching from external control to internal control	Tos	DIN has no impulse input	600			ms
Propagation delay time	Tplz	DIN → DO		155		ns
Input capacitance	Ci				15	pF

**Time sequence characteristics**

Parameter name	symbol	Testing condition	Min. value	Typical value	Max. value	Unit	
Input 0 code,high level time	T0H	VDD=5.0V GND=0V	310	360	410	ns	
Input 1 code,high level time	T1H		650	720	1000	ns	
Output 0 code,high level time	T0H'			350		ns	
Output 1 code,high level time	T1H'			700		ns	
0 code or 1 code cycle	T0/T1				1.25		μs
Reset code, low level time	Treset			200		20000	μs

- (1) When 0 code or 1 code cycle is within the range of 1.25μs (frequency 800KHz) to 2.5μs (frequency 400KHz), the chip can normally work, but the high level time of 0 code and 1 code must accord with the corresponding values in the above table;  
 (2) When reset is not required, the low level time between bytes should not exceed 50μs, or else the chip may be reset to receive data again, which cannot achieve correct data transmission.

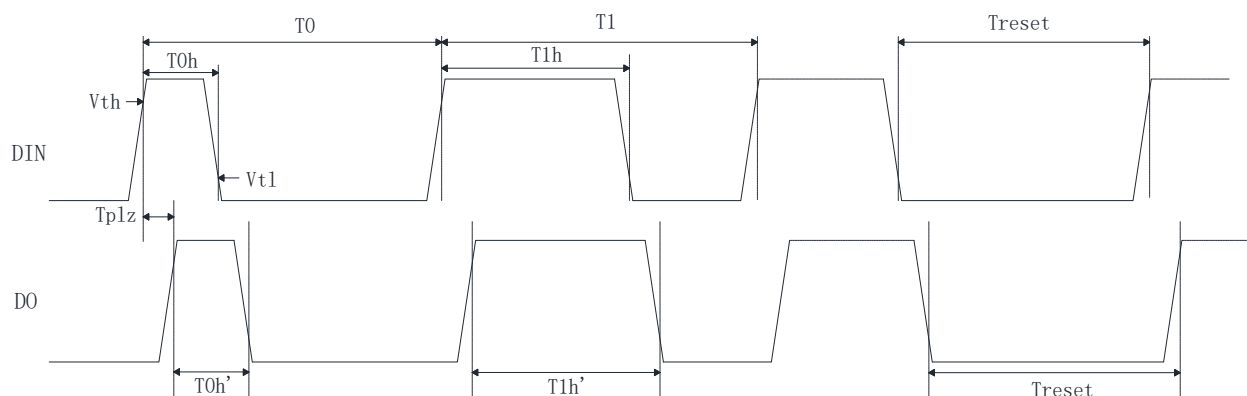

Figure 4

**Function description**

After power-on reset, it receives the data sent from DIN port. When the 24-bit data are received, DO port will start to forward the data continuously sent from DIN port, which provides input data for the next cascaded chip. Prior to forwarding data, DO port is always at low level. If DIN port is input with Reset signals, chip OUT port will output the PWM waveform of corresponding duty ratio according to the received 24-bit data, and the chip will wait to receive new data again. Upon receiving the initial 24-bit data, DO port will forward the data. Before the chip receives no Reset signal, the original output of OOUTR, OOUTG and OOUTB remains unchanged.

The chip adopts auto integer forwarding technology, so that the signals will not distort and attenuate. For all the cascaded chips, the cycles of data transmission are consistent.

**1. Structure of a complete frame of data**

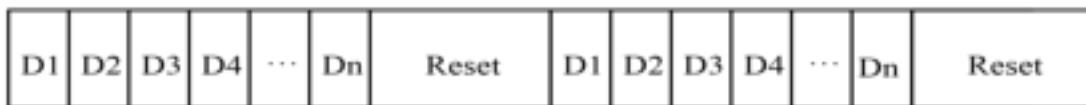

The data formats of D1, D2, D3, D4,...Dn are the same, wherein D1 means the data packet of the first cascaded chip and Dn means the data packet of the n<sup>th</sup> chip. Each data packet contains 24 data bits. Reset means reset signal, valid at low level.

**2. Data format of Dn**

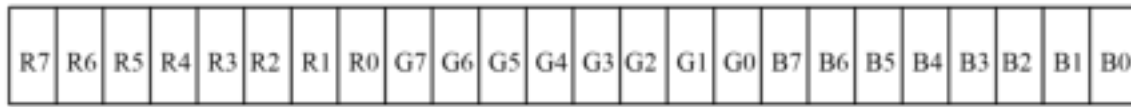

Each data packet contains 8×3 bits, with higher bit sent first.

R[7:0]: used to set the PWM duty ratio output by OOUTR. Full 0 code is off, full 1 code is of maximum duty ratio, 256-level adjustable.

G[7:0]: used to set the PWM duty ratio output by OOUTG. Full 0 code is off, full 1 code is of maximum duty ratio, 256-level adjustable.

B[7:0]: used to set the PWM duty ratio output by OOUTB. Full 0 code is off, full 1 code is of maximum duty ratio, 256-level adjustable.

**3. Data reception and forwarding**

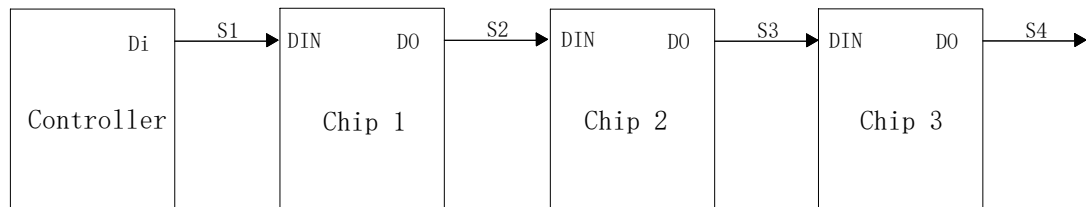

Figure 5

Wherein, S1 is the data sent by the controller, S2, S3 and S4 are the data forwarded by cascaded TM1903. Controller Di Port Data Structure : D1D2D3D4.....Dn.

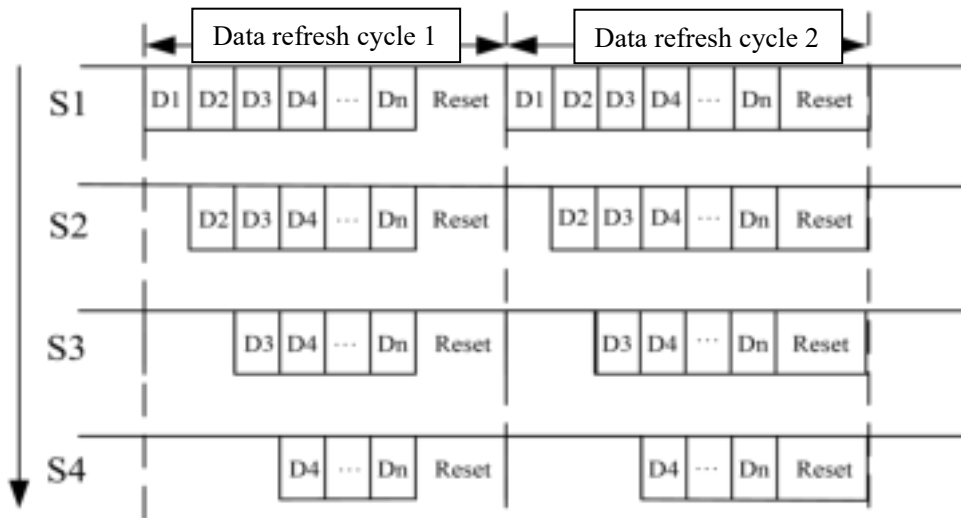

Figure 6

The data reception and forwarding process when the chip is cascaded is as follows: controller sends data packet D1, chip 1 receives the first set of 24-bit data, at this time, chip 1 forwards nothing; then, controller sends data packet D2, chip 1 receives the second set of 24-bit data, because chip 1 has already had the first set of 24-bit data, chip 1 forwards the second set of 24-bit data to chip 2 through DO, chip 2 receives data packet D2 forwarded by chip 1, at this time, chip 2 forwards nothing; then, controller sends data packet D3, chip 1 forwards the received third set of 24-bit data to chip 2, because chip 2 has already had the second set of 24-bit data, chip 2 forwards the third set of 24-bit data to chip 3, chip 3 receives the third set of 24-bit data; and so forth, all the cascaded chips will obtain their own display data. At the moment, if the controller sends a Reset signal, all the chips will reset and control the received 24-bit data to output them from OUT port after decoding, which completes a data refresh cycle and makes the chip return to the reception-ready state. Reset is valid at low level. To make the chip reset, the low level time should be maintained at more than 200 $\mu$ s. Please be noted that the low level time should not be more than 20000 $\mu$ s, or else the chip might be close output.

## Application information

### 1. Typical application circuit

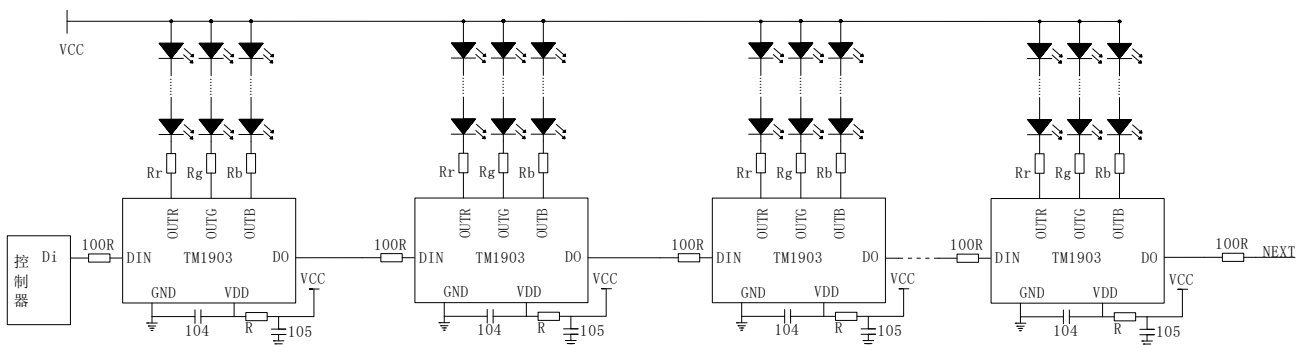

Figure 7

To prevent chip signal input/output pin damage caused by the transient peak voltage generated by hot plugging when the product is tested, 100 $\Omega$  protective resistors should be connected in parallel at signal input and output pins. Besides, the 104 decoupling capacitance of each chip in the figure is indispensable, and the

## Dedicated Circuit for 3-channel LED Constant Current Drive TM1903

wiring to the VDD and GND pins of the chips should be as short as possible, in order to achieve optimal decoupling effect and stable chip operation.

### 2. Power configuration

TM1903 can be configured with DC6-24V power supply, but different power resistors should be configured according to different input voltages. Calculation method of resistance: when the current of VDD port is 10mA, VDD series resistance  $R = (DC-5.5V) \div 10mA$  (DC is supply voltage).

Typical values of configured resistors are as shown in the following table:

Supply voltage (DC)	Suggested power interface and VDD series resistance value
5V	No need of connection of resistors
6V	50Ω
9V	350Ω
12V	650Ω
24V	1.8KΩ

### 3. How to calculate the data refresh rate

The data refresh time is calculated according to how many pixel points are cascaded in one system. A set of RGB is usually a pixel (or a segment), a TM1903 chip can control a set of RGB.

Calculated according to the normal mode:

1-bit data cycle is 1.25μs (frequency 800KHz), and 1-pixel data contains R (8 bits), G (8 bits) and B (8 bits), totally 24 bits. The transmission time is  $1.25\mu s \times 24 = 30\mu s$ . If one system contains 1,000 pixel points, the time for refreshing full display once is  $30\mu s \times 1000 = 30ms$  (omitting Reset signal time), i.e., the refresh rate of one second is:  $1 \div 30ms \approx 33Hz$ .

The following table shows the highest data refresh rates corresponding to cascaded pixel points:

Pixel points	Normal mode	
	Fastest time for refreshing data once (ms)	Highest data refresh rates (Hz)
1~400	12	83
1~800	24	41
1~1000	30	33

### 4. How to make TM1903 work under optimal constant current state

TM1903 applies to constant current drive. According to the constant current curve, when OUT port voltage reaches 0.8V, TM1903 will enter the constant current state. However, it does not mean it is better when the voltage is higher, because when the voltage is higher, the power consumption of the chip will be larger and the heating will be more serious, which lowers the reliability of the whole system. It is suggested that the voltage is 1.2-3V when OUT port is opened. Series resistance can be adopted to lower the excessive voltage of OUT port. The following is the calculation method for selecting resistance values:

System drive voltage: DC

Single LED breakover voltage drop:  $V_{led}$

Series LED number: n

Constant current value:  $I_{out}$

Constant current voltage: 1.5V

Resistance: R

$R = (DC - 1.5V - V_{led} \times n) \div I_{out}$

For example, system power supply: DC24V, single LED breakover voltage drop: 2V, number of series LED: 6, constant current value: 14mA, calculated according to the above formula:  $R = (24V - 1.5V - 6 \times 2V) \div 14mA \approx 750\Omega$ . Only need to connect in series about 750Ω resistance at OUT port. In addition, if it is necessary to consider the long-distance cascade of light strips, there will be a voltage drop at the farthest end of the power supply. The constant current voltage can be increased from 1.5V to 3V. At this time,  $R = (24V - 3V - 2V \times 6) \div 14mA = 643\Omega$ .

**5. How to use TM1903 current expansion**

The output constant current of each OUT port of TM1903 is 18mA. If the user needs to expand the drive current, it can be used after the three OUT ports of RGB are short-circuited. The maximum constant current value will be increased by 18mA once every OUT port is short-circuited. After all the three OUT ports are short-circuited, the maximum constant current value can be 54mA. This method should be used along with software, respectively writing three sets of register values, which can realize accurate current control and larger drive current.

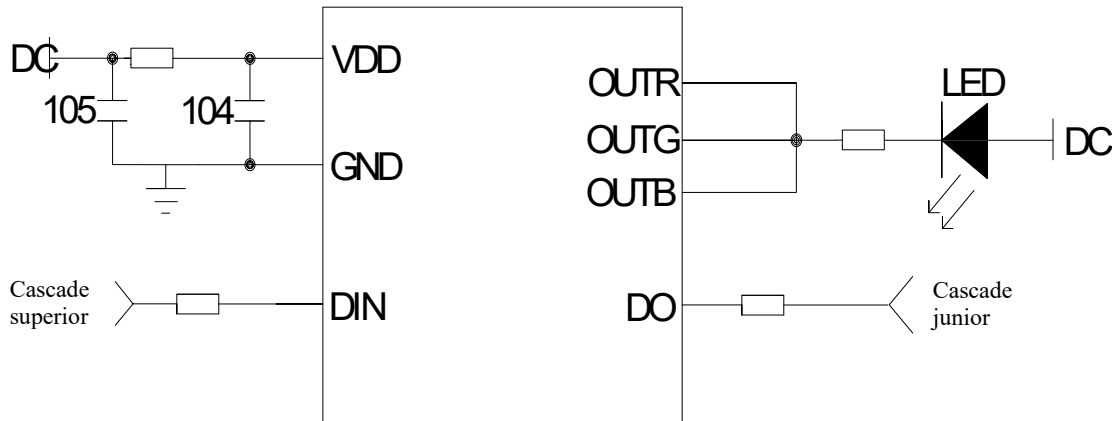

Figure 8

**Constant current curve**

When TM1903 is applied in LED product design, the current difference between channels and chips are very small. When the voltage of the load end changes, the stability of its output current will not be affected. The constant current curve is as shown in the following figure:

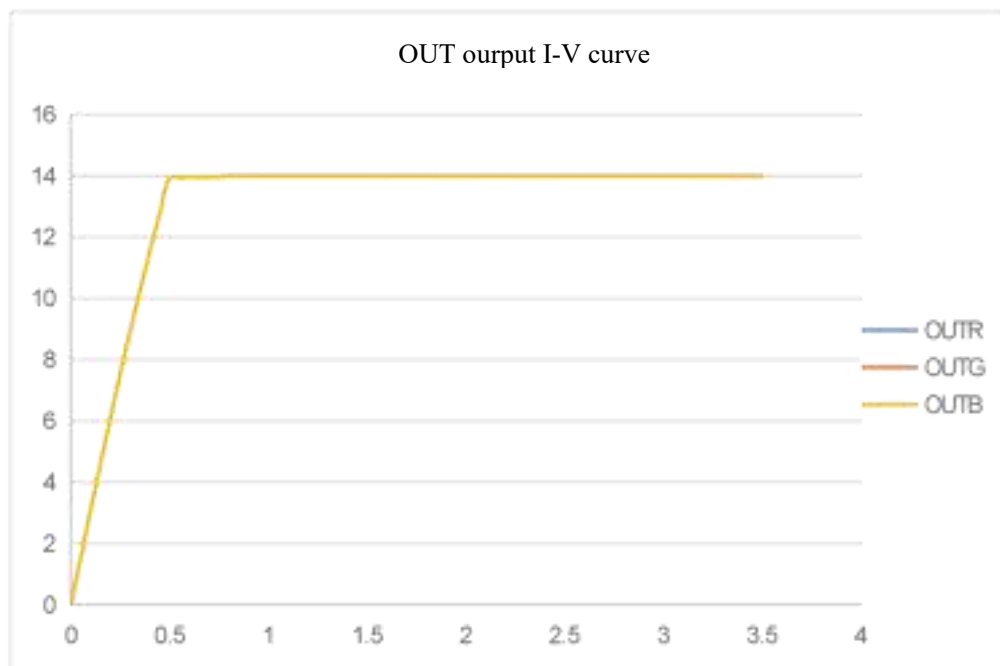
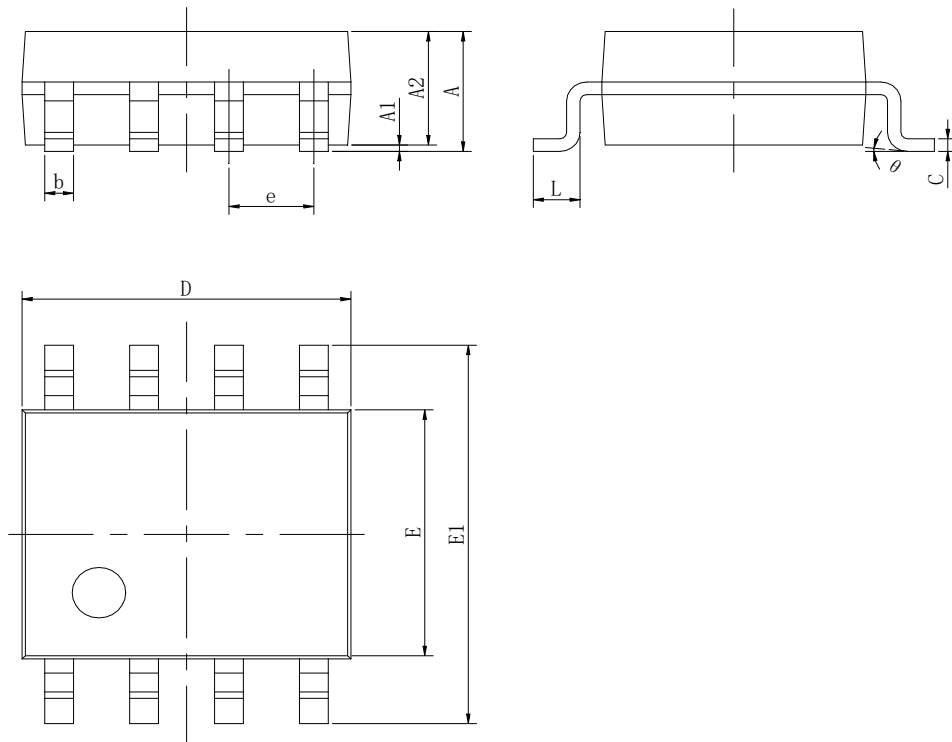
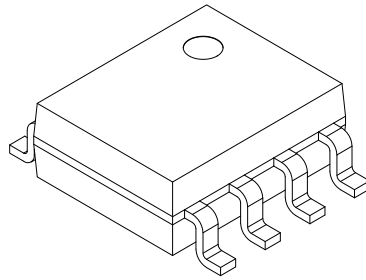

Figure 9



Packaging diagram (SOP8)



Symbol	Dimensions In Millimeters		Dimensions In Inches	
	Min	Max	Min	Max
A	1.350	1.750	0.053	0.069
A1	0.100	0.250	0.004	0.010
A2	1.350	1.550	0.053	0.061
b	0.330	0.510	0.013	0.020
c	0.170	0.250	0.006	0.010
D	4.700	5.100	0.185	0.200
E	3.800	4.000	0.150	0.157
E1	5.800	6.200	0.228	0.244
e	1.270(BSC)		0.050(BSC)	
L	0.400	1.270	0.016	0.050
θ	0°	8°	0°	8°

(All specs and applications shown above are subject to change without prior notice.)