

APA-102-1515-256



Features

- RGB Single point of control
- 8Bit(256 level)color set
- IC input voltage 4.5v~5.5v
- 18mA,Contant current output
- Anti-Reflection resin
- View angle : $\geq 120^\circ$ (min 50% brightness)
- High contrast

Applications

- Full color display
- Advertising light boxes
- Soft light bar



DISCLAIMER	3
LIFE SUPPORT POLICY	3
PRODUCT SPECIFICATIONS.....	4
ATTENTION: ELECTROSTATIC DISCHARGE (ESD) PROTECTION	4
LABEL SPECIFICATIONS	5
SPECIFICATIONS RANGE.....	6
PRODUCT FEATURES	7
ELECTRO-OPTICAL CHARACTERISTICS.....	7
PACKAGE OUTLINE DIMENSION AND RECOMMENDED SOLDERING PATTERN FOR REFLOW	
SOLDERING	7
RECOMMENDED WORKING PARAMETERS	8
TIMING PARAMETERS (T=25°C, VCC=5V).....	9
LOGIC LEVEL NORMAL OPERATING RANGE (TA = -20 TO +80 ° C, VSS = 0 V).....	9
APPLICATION CIRCUIT	9
CASCADING DATA STRUCTURE	10
PRECAUTION FOR USE.....	11
PACKAGING	12
TAPE DIMENSION	12
REEL DIMENSION.....	13
PACKING.....	13
DRY PACK	14
BAKING.....	14
PRECAUTIONS	14
REFLOW SOLDERING	15
REWORKING.....	15
CLEANING.....	15
CAUTIONS OF PICK AND PLACE	16
REVISE HISTORY	16

DISCLAIMER

APA reserves the right to make changes without further notice to any products herein to improve reliability, function or design. APA does not assume any liability arising out of the application or use of any product or circuit described herein; neither does it convey any license under its patent rights, nor the rights of others.

Life Support Policy

APA products are not authorized for use as critical components in life support devices or systems without the express written approval of the President of APA or APA

INTERNATIONAL. As used herein:

1. Life support devices or systems are devices or systems which, (a) are intended for surgical implant into the body, or (b) support or sustain life, and (c) whose failure to perform when properly used in accordance with instructions for use provided in the labeling, can be reasonably expected to result in a significant injury of the user.
2. A critical component in any component of a life support device or system whose failure to perform can be reasonably expected to cause the failure of the life support device or system, or to affect its safety or effectiveness.

Product Specifications

Item	Specification	Material	Quantity
Luminous Intensity(Iv)	Red : 100~210 mcd Green : 210~320 mcd Blue : 58~75 mcd IC@4.5V, R/G/B@18mA Ts= 25 ^o C; Tolerance ±10%		
Wavelength	Red : 620~625 nm Green : 520~535 nm Blue : 460~472 nm IC@4.5V, R/G/B@18mA Ts= 25 ^o C; Tolerance ±10%		
Applied voltage	5V_DC		
View angle	120 ^o		
Resin	Clear	Epoxy	
Carrier tape		Conductive black tape	3000 ea/reel
Reel		Conductive black	
Label	HT standard	Paper	
Packing bag	220x240mm	Aluminum laminated bag/ no-zipper	One reel per bag
Carton	HT standard	Paper	Non-specified

Others: PWM-20KHZ

Each immediate box consists of 5 reels. The 5 reels may not necessarily have the same lot number or the same bin combinations of Iv, λ_D and Vf. Each reel has a label identifying its specification; the immediate box consists of a product label as well.

Note :This is shipped test conditions

※Remarks: This product should be operated in forward bias. If a reverse voltage is continuously applied to the product, such operation can cause migration resulting in LED damage.

ATTENTION: Electrostatic Discharge (ESD) protection



The symbol to the left denotes that ESD precaution is needed. ESD protection for GaP and AlGaAs based chips is necessary even though they are relatively safe in the presence of low static-electric discharge. Parts built with AlInGaP, GaN, or/and InGaN based chips are **STATIC SENSITIVE devices**. ESD precaution must be taken during design and assembly.

If manual work or processing is needed, please ensure the device is adequately protected from ESD during the process.

Label Specifications

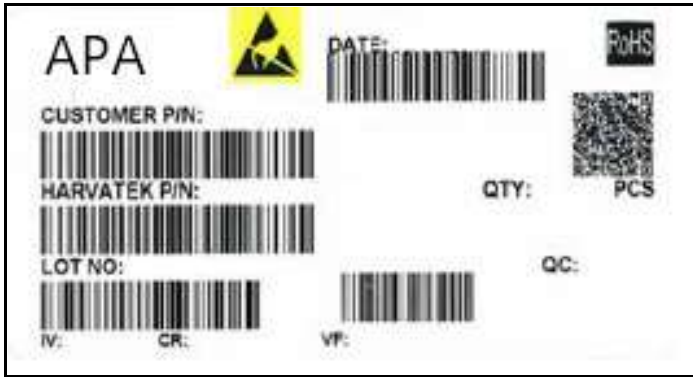

■ APA P/N: APA-102-1515-256

102

1515

256

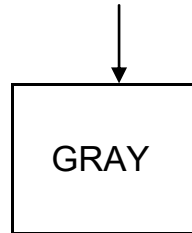
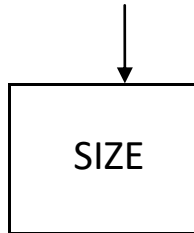
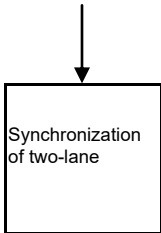

■ Lot No.:

1	2	3	4	5	6	7	8	9	10
E	1	A	1	A	2	2	L	1	2
Code 1 2		Code 3	Code 4	Code 5	Code 6	Code 7	Code 8	Code 9	Code 10
		Mfg. Year	Mfg. Month	Mfg. Date	Consecutive number		Special code		
Internal Tracing Code		2010-A		1:A	01~ZZ		000~ZZZ		
		2011-B		2:B					
		2012-C	1:Jan.	3:C					
		...	2:Feb.	...					
		2018-I/J	...	26:Z					
		2019-K	A:Oct.	27:7					
		...	B:Nov.	28:8					
2022-N	C:Dec.	29:9							
2023-P		30:3							
...		31:4							

Specifications Range

■ Luminous Intensity (Iv) :

Color	Spec. Range
R	100-210 mcd
G	210-320 mcd
B	58-75 mcd

Note: It maintains a tolerance of $\pm 10\%$ on luminous intensity

■ Wavelength :

Color	Spec. Range
R	620-625 nm
G	520-535 nm
B	460-472 nm

Note: It maintains a tolerance of $\pm 0.5\text{nm}$ on Wavelength Bin

Product Features

Electro-Optical Characteristics

(T_{Soldering} = 25 °C)

Series	Emitting Color	Material	Wavelength λ(nm)			I _v (mcd) Typical	Viewing Angle 2θ _{1/2}
			λ _D	λ _P	Δ λ		
B3DK3BRG	R	AllnGaP	624	630	18	150	120
	G	InGaN	523	518	35	260	120
	B	InGaN	470	465	25	66	120

Package Outline Dimension and Recommended Soldering Pattern for Reflow Soldering

(Unit:mm Tolerance: +/-0.1)

Outline Dim.	Soldering Pattern
<p>Soldering terminals may shift in the x, y direction.</p>	

Electrical characteristics (Ta = 25°C, Vss = 0 V)

(T_{Soldering} 25 °C)

Parameter	Symbol	Range	Unit
Voltage	VDD	2.5~7.5	V
LED lamp voltage	VLED	3~7.5	V
Data clock frequency	FCLK	15	MHZ
Maximum LED output current	Iomax	18	mA
Channel current deviation	DI0	On-chip <3%, between sheets <5%	%
Power loss	PD	<400	mW
Welding temperature	TM	300(8S)	°C
Operating temperature	Topt	-30~+85	°C
Storage temperature	Tstg	-60~+120	°C

Recommended working parameters

Parameter	Symbol	Range	Unit
Supply voltage	VDD	4.5~5.5	V
LED lamp voltage	VLED	3~7.5	V
Regulated output voltage	VOUT	4.5±0.3%	V
Input voltage	VIN	-0.4-VOUT+0.4	V
Data clock frequency	FCLK	0-5	MHZ
Clock high width	TCLKH	>30	ns
Clock low width	TCLKL	>30	ns
Time when data was created	TSETUP	>10	ns
Data retention time	THOLD	>5	ns
Power consumption	PD	<300	mW
Operating temperature	TOP	-25~+80	°C

Timing parameters (T=25°C, VCC=5V)

Parameter	Symbol	Range		Unit
Input signal maximum rise and fall times	TR	VCC=5V	<500	ns
Input signal maximum rise and fall times	TF	VCC=5V	<400	ns
Cascaded output signal maximum rise and fall times e	TTHH	CL=30pF , RL=1K	<15	ns
Cascaded output signal maximum rise and fall times	TTHL	CL=30pF , RL=1K	<15	ns
Cascaded output signal maximum delay time	TPD	CL=30pF , RL=1K	<15	ns
Cascaded output signal maximum delay time	TCO	CL=30pF , RL=1K	<15	ns
Drive output minimum PWM turn-on width	TONMIN	IOUT=0~20mA	200	ns
Drive output signal maximum on and off time	TON	IOUT=0~20mA	<80	ns

Logic level normal operating range (Ta = -20 to +80 ° C, Vss = 0 V)

Parameter	Symbol	Minimum	Typical	Maximum	Unit	Test Conditions
Logic supply voltage	VDD	-	5	-	V	-
High level input voltage	VIH	0.7 VDD	-	VDD	V	-
Low level input voltage	VIL	-	-	0.3 VDD	V	-

Application circuit

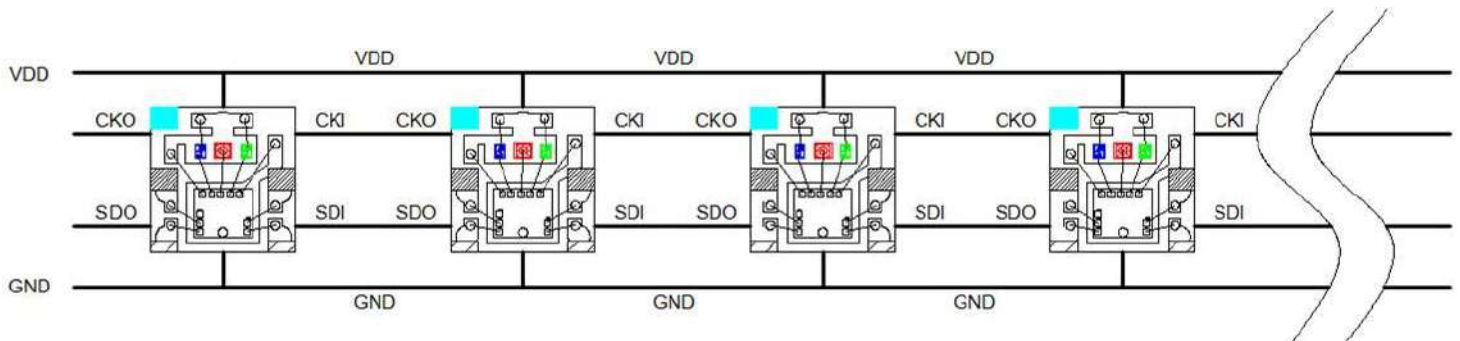

Cascading data structure

Communication protocol and timing:

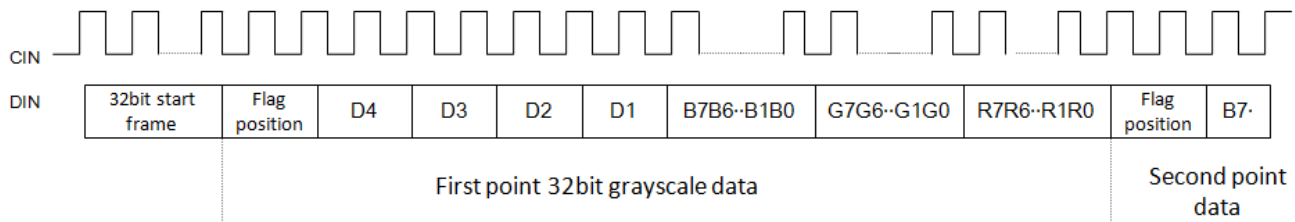
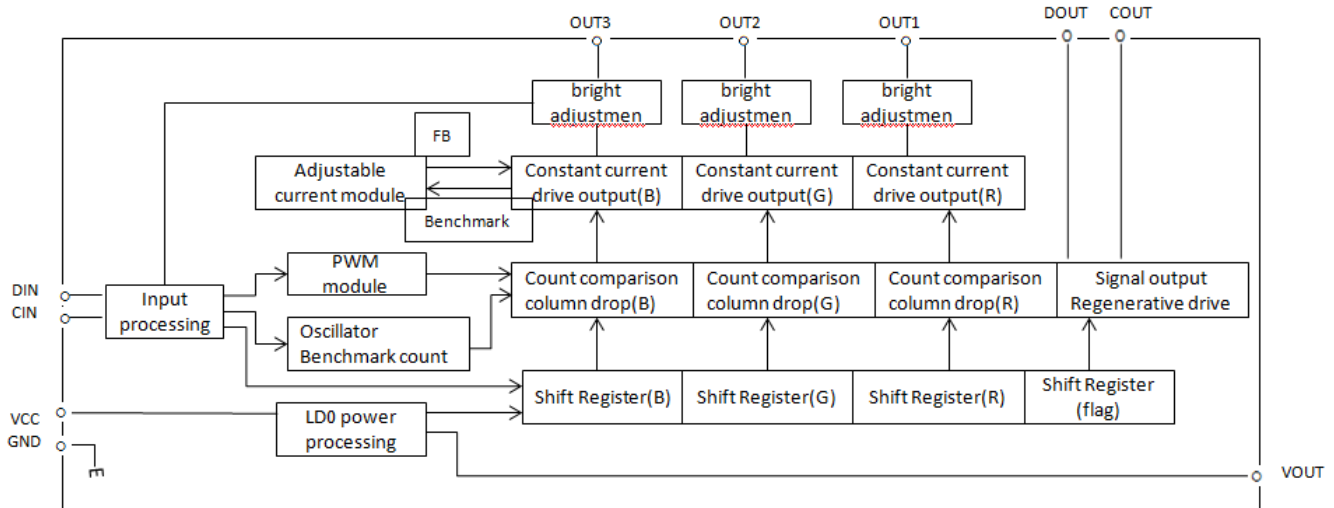

1. The first 32 bits of "0" are the start frame, which is entered on the rising edge of Cin, and the timing DIN is prior to CIN.
2. The flag is three "1"
3. D4, D3, D2, D1 and D0 are 32 levels of brightness adjustment, D4 is the highest level
4. Gray level data should be high first, and it is blue green and red order

Precaution for Use

1. The chips should not be used directly in any type of fluid such as water, oil, organic solvent, etc.
2. When the LEDs are illuminating, the maximum ambient temperature should be first considered before operation.
3. LEDs must be stored in a clean environment. A sealed container with a nitrogen atmosphere is necessary if the storage period is over 3 months after shipping.
4. The LEDs must be used within 4 weeks after unpacked. Unused products must be repacked in an anti-electrostatic package, folded to close any opening and then stored in a dry and cool space.
5. The appearance and specifications of the products may be modified for improvement without further notice.
6. The LEDs are sensitive to the static electricity and surge. It is strongly recommended to use a grounded wrist band and anti-electrostatic glove when handling the LEDs. If a voltage over the absolute maximum rating is applied to LEDs, it will damage LEDs. Damaged LEDs will show some abnormal characteristics such as remarkable increase of leak current, lower turn-on voltage and getting unlit at low current.

Packaging
Tape Dimension

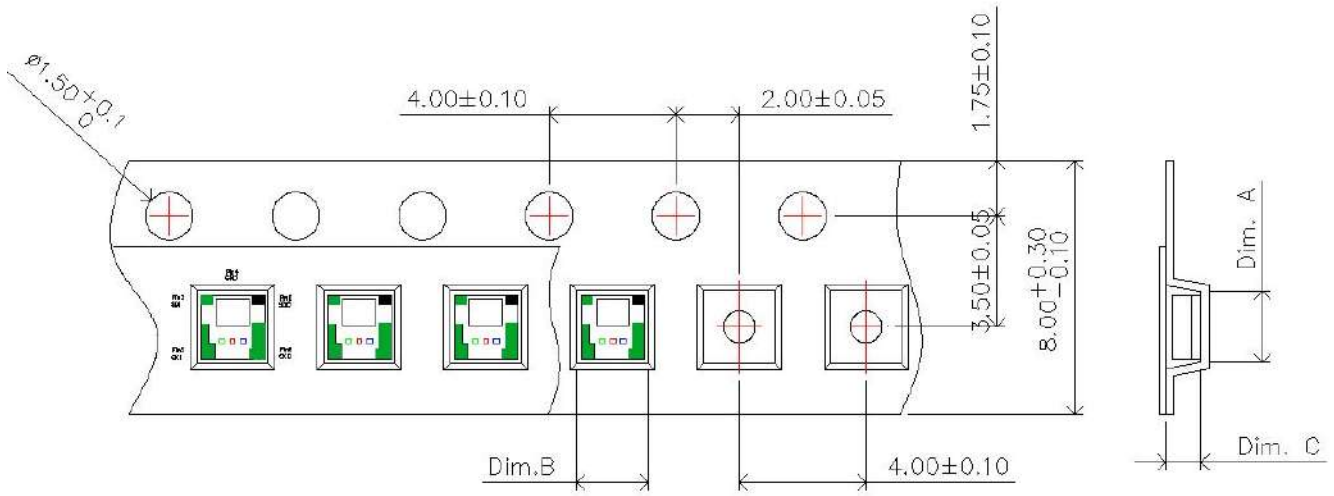

Dim. A	Dim. B	Dim. C	Q'ty/Reel
1.73 ± 0.05	1.73 ± 0.05	1.10 ± 0.05	3K

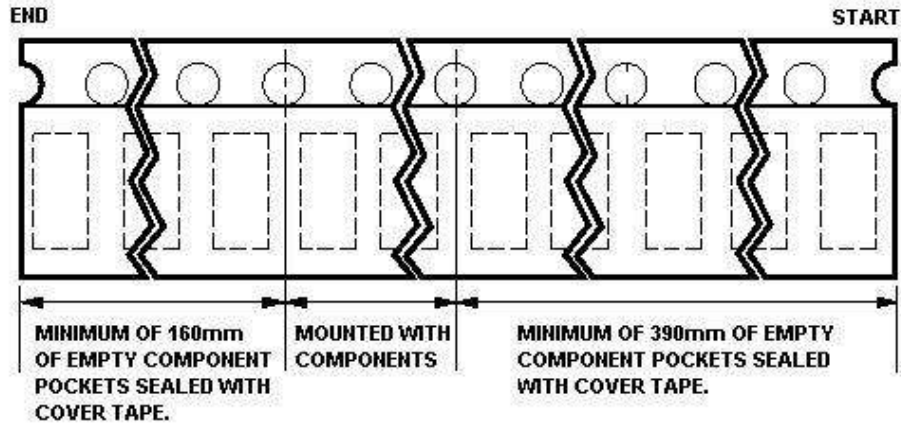

Reel Dimension

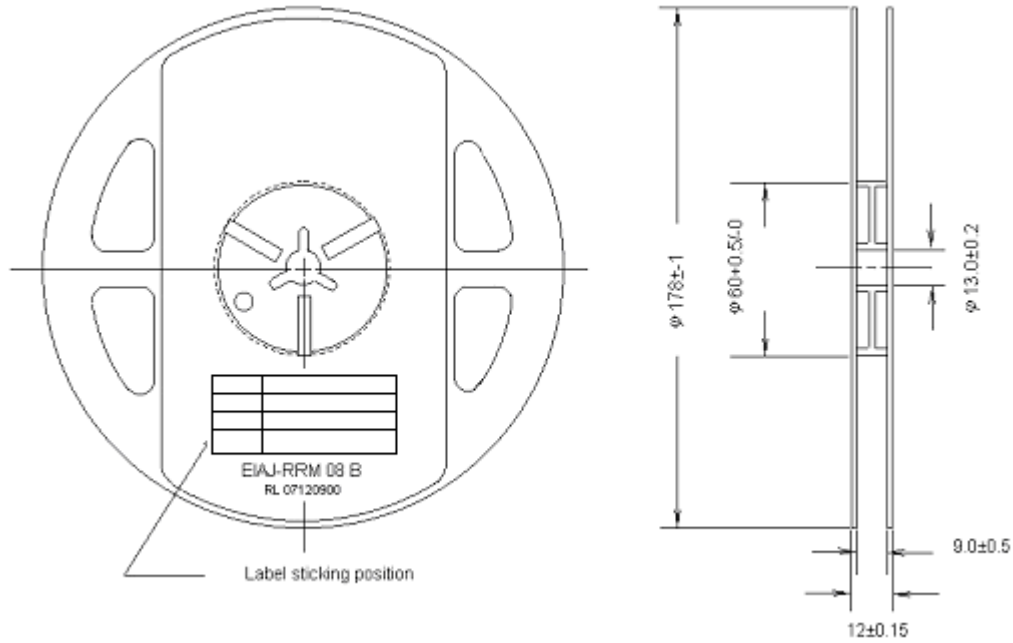

Packing

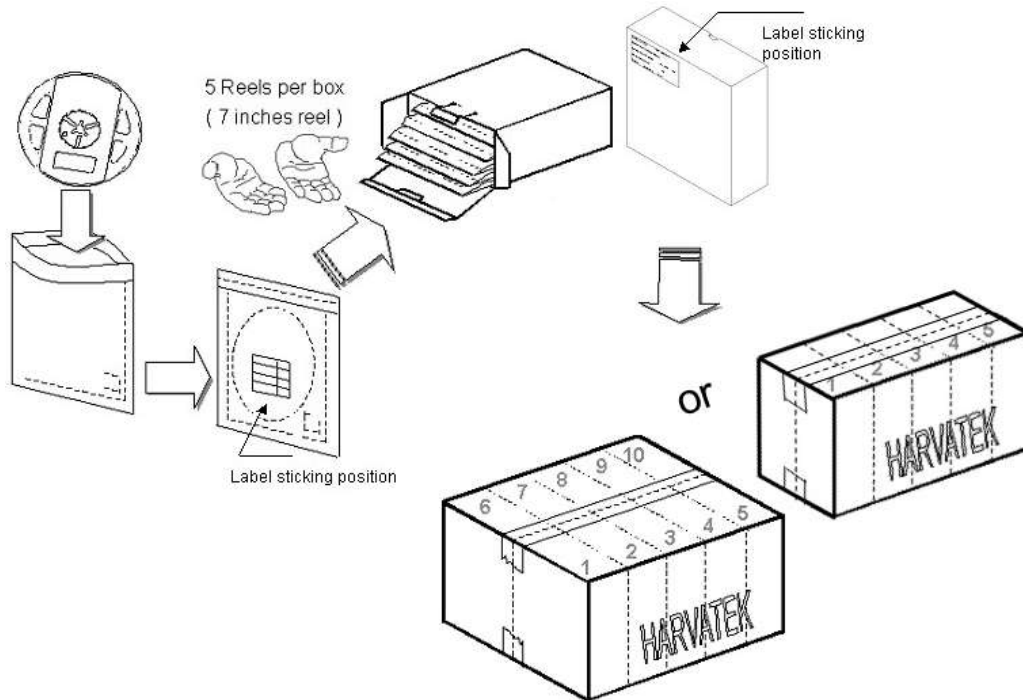

5 or 10 boxes per carton is available depending on shipment quantity.

Dry Pack

All SMD optical devices are **MOISTURE SENSITIVE**. Avoid exposure to moisture at all times during transportation or storage. Every reel is packaged in a moisture protected anti-static bag. Each bag is properly sealed prior to shipment.

A humidity indicator will be included in the moisture protected anti-static bag prior to shipment.

The packaging sequence is as follows:

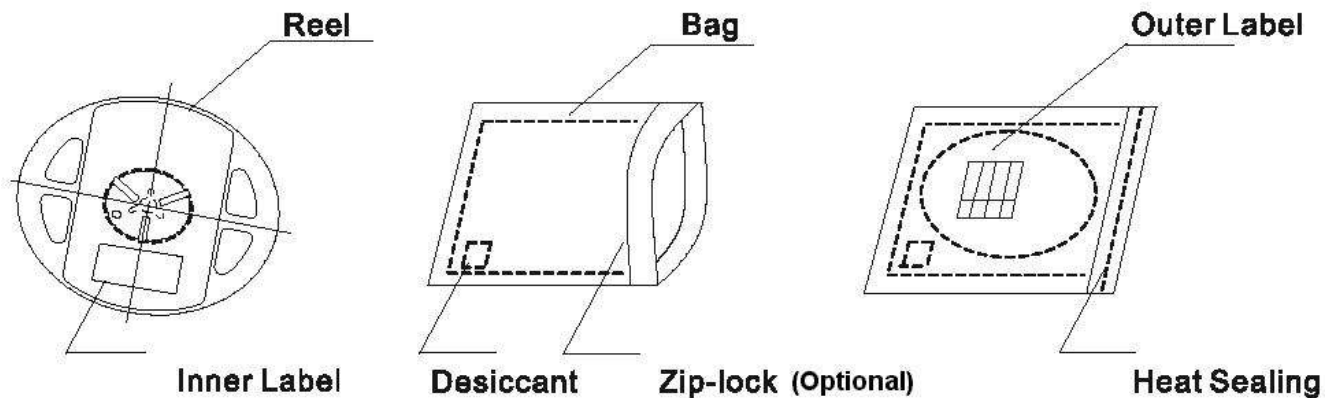

Baking

Baking before soldering is recommended when the package has been unsealed for 4 weeks.

The conditions are as followings:

1. $60\pm 3^{\circ}\text{C} \times (12\sim 24\text{hrs})$ and $< 5\% \text{RH}$, taped reel type.
2. $100\pm 3^{\circ}\text{C} \times (45\text{min}\sim 1\text{hr})$, bulk type.
3. $130\pm 3^{\circ}\text{C} \times (15\text{min}\sim 30\text{min})$, bulk type.

Precautions

1. Avoid exposure to moisture at all times during transportation or storage.
2. Anti-Static precaution must be taken when handling GaN, InGaN, and AlInGaP products.
3. It is suggested to connect the unit with a current limiting resistor of the proper size. Avoid applying a reverse voltage beyond the specified limit.
4. Avoid operation beyond the limits as specified by the absolute maximum ratings.
5. Avoid direct contact with the surface through which the LED emits light.
6. If possible, assemble the unit in a clean room or dust-free environment.

Reflow Soldering

Recommend soldering paste specifications:

1. Operating temp.: Above 220°C ,60 sec.
2. Peak temp.:260 °C Max.,10sec Max.
3. Reflow soldering should not be done more than two times.
4. Never attempt next process until the component is cooled down to room temperature after reflow.
5. The recommended reflow soldering profile (measured on the surface of the LED terminal) is as following:

Lead-free Solder Profile

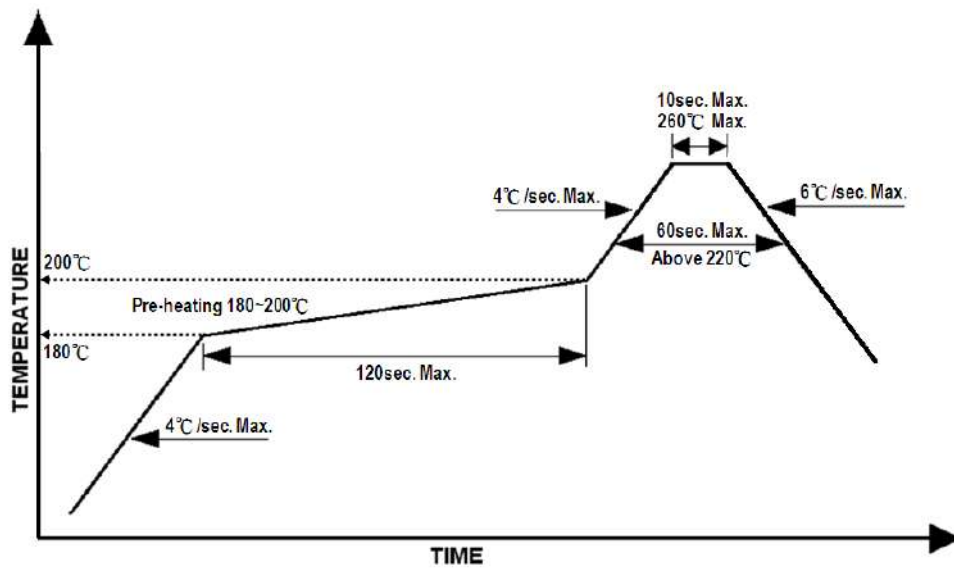

Reworking

- Rework should be completed within 5 seconds under 260 °C .
- The iron tip must not come in contact with the copper foil.
- Twin-head type is preferred.

Cleaning

Following are cleaning procedures after soldering:

- An alcohol-based solvent such as isopropyl alcohol (IPA) is recommended.
- Temperature x Time should be 50°C x 30sec. or <30°C x 3min
- Ultrasonic cleaning: < 15W/ bath; bath volume ≤ 1liter
- Curing: 100 °C max, <3min

