

Bluetooth & RF 3 in 1 LED Controller

Model No.: V3-L(WB)

Tuya APP cloud control/Voice control/3 Channels/1-3 color/ Push Dim/Four PWM frequency/Linear or logarithmic dimming

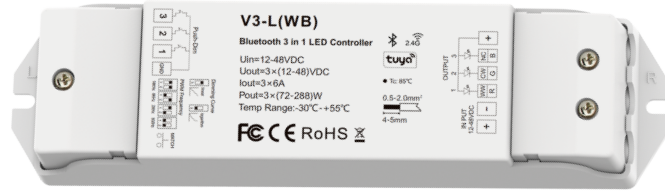

Features

- 3 in 1 function, used for control RGB, color temperature or single color LED strip.
- DC12-48V input, 3 channel constant voltage output.
- Tuya APP cloud control, support on/off, RGB color, color temperature and brightness adjust, delay turn on/off light, timer run, scene edit and music play function.
- Voice control, support amazon ECHO and TmallGenie smart speaker.
- Match with RF 2.4G remote control optional.
- User need set light type by press key before Tuya APP network connection and match RF remote of the same light type.
- Each V3-L(WB) controller can also work as Bluetooth-RF converter, then use Tuya APP to control one or more RF LED controller or RF LED dimming driver synchronously.
- Light on/off fade time 3s selectable.
- Connect with external push key to achieve on/off and 0-100% dimming function.
- Logarithmic or linear dimming curve selectable.
- PWM frequency 500Hz, 2KHz, 8KHz or 16KHz selectable.
- Overheat / Overload / Short circuit protection, recover automatically.

Technical Parameters

Input and Output		Dimming data	
Input voltage	12-48VDC	Input signal	Tuya APP + RF 2.4GHz + Push Dim
Input current	18.5A	Control distance	30m(Barrier-free space)
Output voltage	3 x (12-48)VDC	Dimming gray scale	4096 (2 ¹²) levels
Output current	3CH,6A/CH	Dimming range	0-100%
Output power	3 x (72-288)W	Dimming curve	Logarithmic or linear
Output type	Constant voltage	PWM Frequency	500Hz, 2KHz, 8KHz, 16KHz
Safety and EMC		Warranty and Protection	
EMC standard (EMC)	ETSI EN 301 489-1 V2.2.3 ETSI EN 301 489-17 V3.2.4	Warranty	5 years
Safety standard(LVD)	EN 62368-1:2020+A11:2020	Protection	Reverse polarity Over-heat Over-load Short circuit
Radio Equipment(RED)	ETSI EN 300 328 V2.2.2		
Certification	CE,EMC,LVD,RED		
Environment		Weight	
Operation temperature	Ta: -30°C ~ +55°C	Net weight	0.108kg
Case temperature (Max.)	Tc: +85°C	Gross weight	0.130kg
IP rating	IP20		

FC CE RoHS LVD RED

Mechanical Structures and Installations

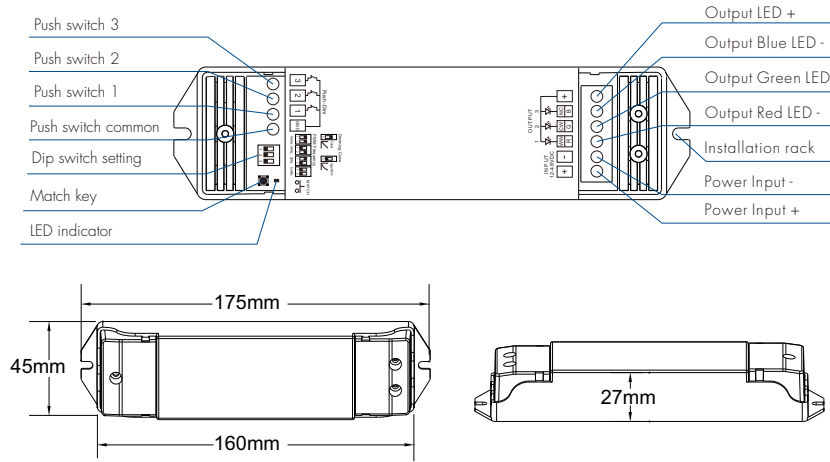

System wiring

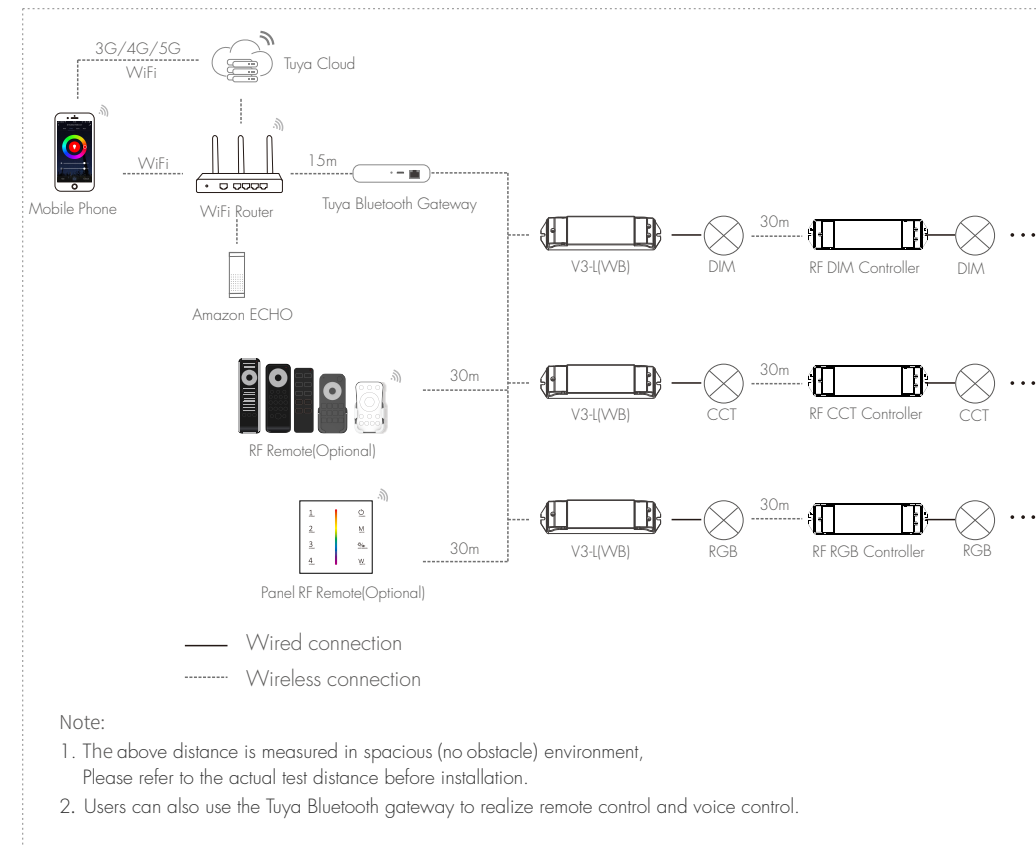

Wiring Diagram

• V3-L(WB) for RGB

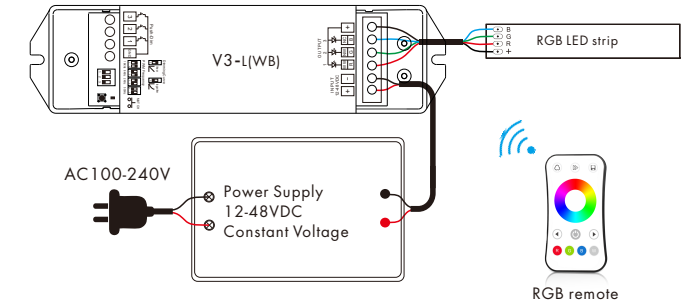

• V3-L(WB) for dual color

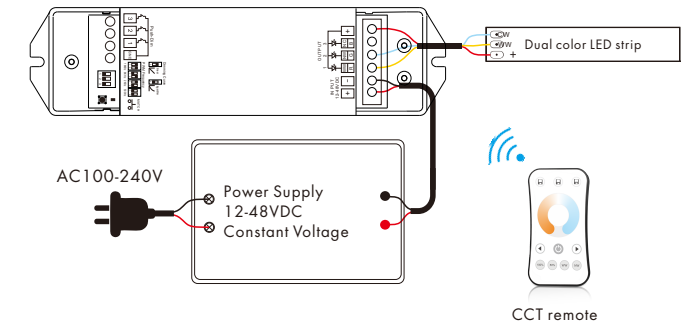

• V3-L(WB) for single color

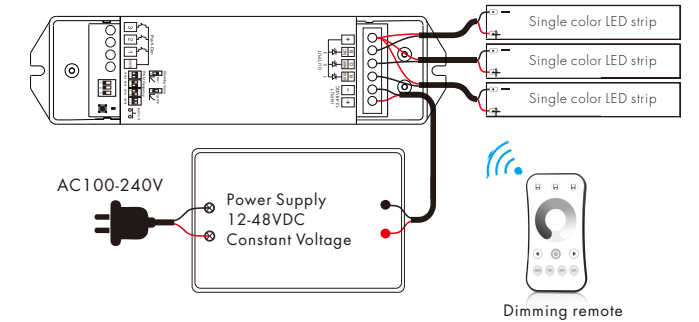

- Note: 1. After changed the light type by DIP switch, please redo the tuya APP config operation.
2. For RGB+CCT or CCT light type, continuous power on and off will change 3 levels color temperature (WW, NW and CW) in sequence.
3. Switch off the power, then switch on power, repeat again.
Immediately short press match key 3 times, the light on/off time will change between 3s and 0.5s.

Tuya APP network connection

Press and hold Match key for 5s, or push twice Match key fastly:
Clear previous network connection, enter config mode, the blue LED indicator fast flash, the output LED will flash 10 times.

Repeat power on and off for 5 consecutive times, also clear previous network connection, enter config mode, the output LED will flash 10 times.

If Tuya APP network connection succeed, the blue LED indicator will stop flash, and in Tuya APP, you can find BT-RGB device (or other DIM, CCT).

Tuya APP interface

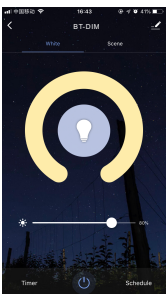

White interface
For DIM type:
Touch brightness slide to adjust brightness.

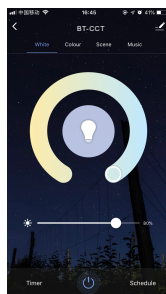

Color temperature interface
For CCT type:
Touch color wheel to adjust color temperature.
Touch brightness slide to adjust brightness.

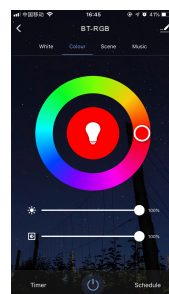

Colour interface
For RGB type:
Touch color wheel to adjust static RGB color.
Touch brightness slide to adjust color brightness.
Touch saturation slide to adjust color saturation, namely gradient from the current color to white (RGB mixed).

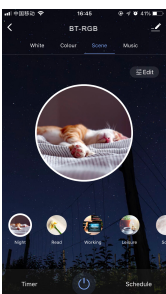

Scene interface
The 1-4 scene is static color for all light type. the inner color of these scene can be editable.
The 5-8 scene is dynamic mode for RGB type, such as green fade in and fade out, RGB jump, 6 color jump, 6 color smooth.

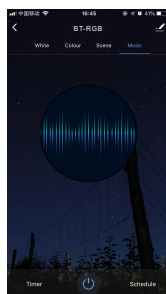

Music, Timer, Schedule
The music play can use smart phone music player or micro-phone as music signal input.
The Timer key can turn on or turn off light in the next 24 hours.
The Schedule key can add multiple timers to turn on or turn off light according to different time periods.

Push-Dim control

Long press one Push key and Match key at the same time to select 3 kinds light type, and each light type will have different push key function.

Long press 1 key and Match key 2 seconds, set as single color type.

Long press 2 key and Match key 2 seconds, set as dual color type.

Long press 3 key and Match key 2 seconds, set as RGB type.

After the light type is set, please repeat network configure operation by Tuya APP.

Single color	1 key	Short press turn on/off 1/2/3 channel, long press 1-6s dim up/down
	2 key	Invalid
	3 key	Invalid
Dual color	1 key	Short press turn on/off light, long press 1-6s dim up/down
	2 key	Short press 3 levels color temperature (WWW, NW, CW), long press 1-6s color temperature up/down
	3 key	Invalid
RGB	1 key	Short press turn on/off light, long press 1-6s dim up/down
	2 key	Short press change dynamic mode, long press 2s to set speed (1-10 levels)
	3 key	Short press change static RGB color (24 levels), long press 1-6s adjust saturation

RGB dynamic mode list

No.	Name	No.	Name
1	RGB jump	6	RGB fade in and out
2	RGB smooth	7	Red fade in and out
3	6 color jump	8	Green fade in and out
4	6 color smooth	9	Blue fade in and out
5	Yellow cyan purple smooth	10	White fade in and out

PWM frequency setting



We can select four PWM frequency: 500Hz, 2KHz, 8KHz or 16KHz.
Higher PWM frequency, will cause lower output current, higher power noise, but more suitable for camera (No flickers for video).

Dimming curve setting

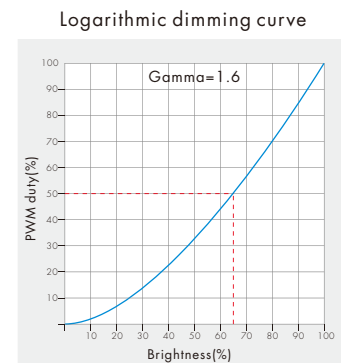
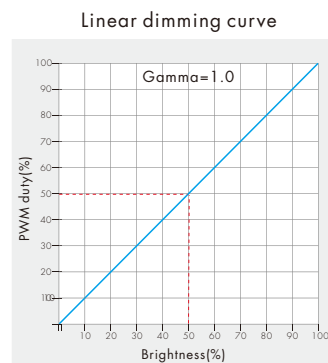

V3-L(WB) match remote control (Optional)

End user can choose the suitable match/delete ways. Two options are offered for selection:

Use the V3-L(WB)'s Match key

Match:
Short press match key of V3-L(WB), immediately press on/off key (single zone remote) or zone key (multiple zone remote) on the remote. The LED indicator fast flash a few times means match is successful.

Delete:
Press and hold match key of V3-L(WB) for 10s, The LED indicator fast flash a few times means all matched remotes were deleted.

Use Power Restart

Match:
Switch off the power of V3-L(WB), then switch on power, repeat again. Immediately short press on/off key (single zone remote) or zone key (multiple zone remote) 3 times on the remote. The light blinks 3 times means match is successful.

Delete:
Switch off the power of V3-L(WB), then switch on power, repeat again. Immediately short press on/off key (single zone remote) or zone key (multiple zone remote) 5 times on the remote. The light blinks 5 times means all matched remotes were deleted.

V3-L(WB) work as Bluetooth-RF converter to match RF LED controller or dimming driver

End user can choose the suitable match/delete ways. Two options are offered for selection:

Use the controller's Match key

Match:
Short press match key of the controller, immediately press on/off key on the Tuya APP. The LED indicator fast flash a few times means match is successful.

Delete:
Press and hold match key of the controller for 5s, The LED indicator fast flash a few times means match was deleted.

Use Power Restart

Match:
Switch off the power of the controller, then switch on power, repeat again. Immediately short press on/off key 3 times on the Tuya APP. The light blinks 3 times means match is successful.

Delete:
Switch off the power of the controller, then switch on power, repeat again. Immediately short press on/off key 5 times on the Tuya APP. The light blinks 5 times means match was deleted.