

---

## 4-channel LED constant current driver UCS2904B

### GENERAL DESCRIPTION

The UCS2904B is a 4-channel LED display driver / controller with a built-in MCU digital interface, data latches and LED high voltage driving functions. It features superior performances and reliable functions. Under the control of the external MCU, it performs independent grayscale control through data-cascading transfer for driving large outdoor colour dot-matrix LED panels.

### FEATURES

1. single line data transmission (return to zero code)
2. shaping transmit specific technology, Cascade number of lamps and lanterns is not restricted
3. cascading ability enhancement technology, Any 2 lanterns spacing can be up to 10 meters
4. Data transfer rate of 800 k/s, Images of not less than 512 points can be realized when the refresh rate of 25 frames per second,
5. 4 PWM output port, easy to control 4 color LED products, Commonly used in RGBW color LED control
5. RGBW output port PWM control can be achieved 256 grey level each port adjustment, port scanning frequency of 1.8 KHz/s
6. chip VDD built-in 5 v voltage regulator tube, output port Withstand Voltage is greater than 24 V
7. adopt the preset 17 mA/channel constant current mode. High precision of constant current , differences of current between Channel is less than  $\pm 1.5\%$ ,the differences of current between Chip is less than  $\pm 3\%$
8. when power up ,IC self-inspection then Light connection on the pin B lamp
9. SA-I Anti-interference patent technology for single line data transmission
10. Industrial design, stable and reliable

### Application:

Point light source    full color module    full color light bar    LED decorate..

## PIN CONFIGURATION

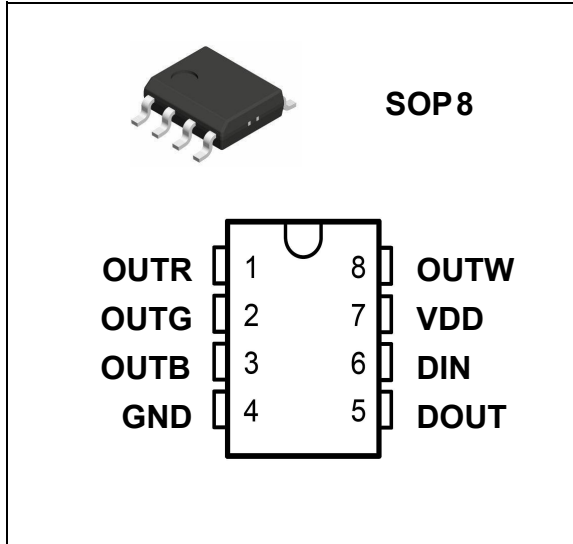

## PIN DESCRIPTION

Number	Symbol	Name	Function Description
1	OUTR	LED drive output	Red PWM control output
2	OUTG	LED drive output	Green PWM control output
3	OUTB	LED drive output	Blue PWM control output
4	GND	Ground	Ground
5	DOUT	Data output	Display data cascaded output
6	DIN	Data input	Display data cascaded input
7	VDD		Logic power supply
8	OUTW	LED drive output	White PWM control output

**ABSOLUTE MAXIMUM RATINGS** ( $T_A = 25\text{ }^\circ\text{C}$ ,  $V_{SS} = 0\text{ V}$ , unless otherwise specified )

Parameter	Symbol	Value	Unit
Logic supply voltage	$V_{DD}$	+ 7.0	V
Output port limitation voltage	$V_{OUT}$	28	V
Logic input voltage	$V_I$	- 0.5 to $V_{DD} + 0.5$	V
Operating temperature	$T_{OPT}$	- 40 to + 85	$^\circ\text{C}$
Storage temperature	$T_{STG}$	- 55 to + 150	$^\circ\text{C}$
antistatic	ESD	6 0 0 0	V
output rating	Pd	4 0 0	mW

**RECOMMENDED OPERATING RANGES** ( $T_A = -20$  to  $+70\text{ }^\circ\text{C}$ ,  $V_{SS} = 0\text{ V}$ , unless otherwise specified)

Parameter	Symbol	Min.	Typ.	Max	Unit
Logic supply voltage	$V_{DD}$	-	5.5	-	V
High level input voltage	$V_{IH}$	$0.7 V_{DD}$	-	$V_{DD}$	V
Low level input voltage	$V_{IL}$	0	-	$0.3 V_{DD}$	V
Output port rated voltage	Vout	24			V

**ELECTRICAL CHARACTERISTICS** ( $T_A = -20$  to  $+70\text{ }^\circ\text{C}$ ,  $V_{DD} = 4.5$  to  $5.5\text{ V}$ ,  $V_{SS} = 0\text{ V}$ , unless otherwise specified)

Parameter	Symbol	Min.	Typ.	Max	Unit	Test conditions
Low level output current	Iout	16.5	17	17.5	mA	R, G, B, W
Low level output current	I <sub>do</sub>	10	-	-	mA	$V_o = 0.4\text{ V}$ , Dout
High level input voltage	V <sub>ih</sub>	$0.6V_{DD}$	-		V	
Low level input voltage	V <sub>il</sub>	-	-	$0.3 V_{DD}$	V	
Voltage hysteresis	V <sub>h</sub>	-	0.35	-	V	
quiescent current	I <sub>DDdyn</sub>			1	mA	无负载
rated power	PD			250	mW	( $T_a=25\text{ }^\circ\text{C}$ )
thermal resistance	R <sub>th(j-a)</sub>		80	190	$^\circ\text{C}/\text{W}$	

**SWITCHING CHARACTERISTICS** ( $T_A = -20$  to  $+70$  °C ,  $V_{DD} = 4.5$  to  $5.5$  V,  $V_{SS} = 0$  V, unless otherwise specified )

Parameter	Symbol	Min.	Typ.	Max	Unit	Test conditions
Propagation delay time	$t_{PLZ}$	-	-	300	ns	$C_L = 15$ pF, DIN → DOUT, $R_L = 10$ kΩ
Fall time	$t_{THZ}$	-	-	120	μs	$C_L = 300$ pF, OUTR/OUTG/OUTB
Data transfer rate	$F_{MAX}$	800	-	-	kbps	50 % duty cycle
Input capacitance	$C_I$	-	-	15	pF	-

**constant current characteristic**

UCS2904B Constant current characteristic is excellent, between Channel, even between chip, the differences of current is tiny

(1): the differences of current between Channel is less than  $\pm 1.5\%$ 。 the differences of current between Chip is less than  $\pm 3\%$

(2): When the voltage of the load change, UCS2904B output current is not affected, as shown in the figure below

(3): Below UCS2904B output port of the current  $I_{out}$  and add on the port voltage  $V_{ds}$  curve relationship。 the smaller the  $I_{out}$  current, the smaller in the condition of constant current need of  $V_{ds}$ .

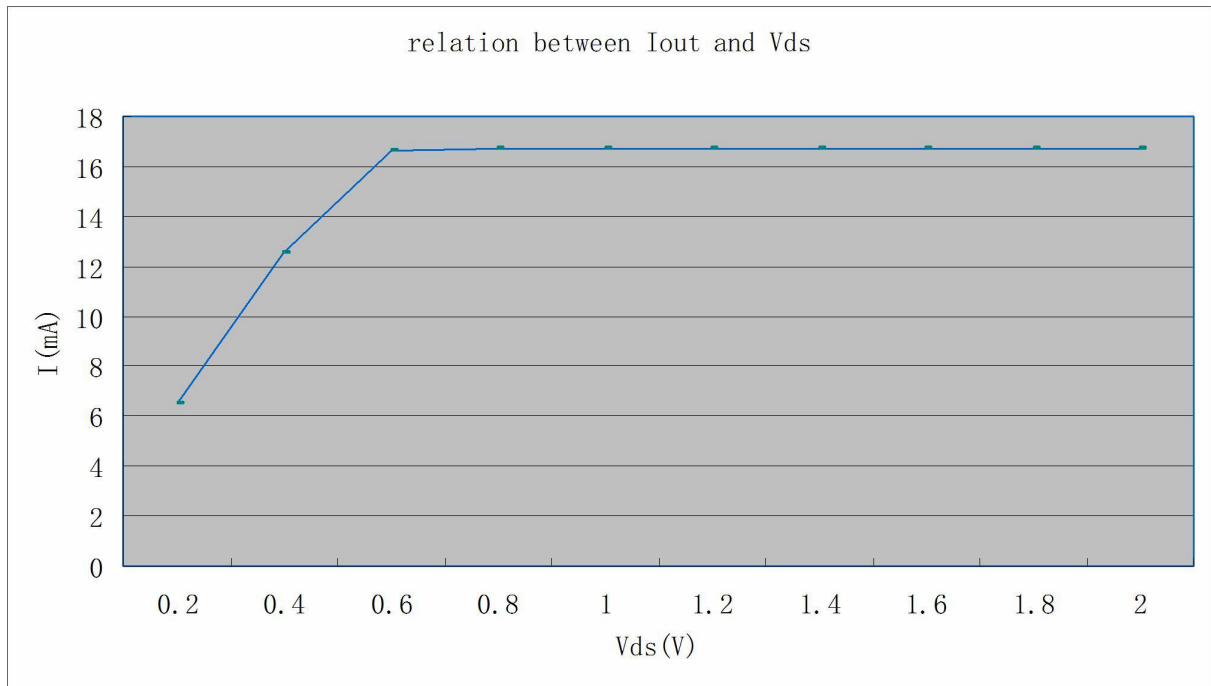

**Typical Application circuit diagram**

1. Power voltage is 5V

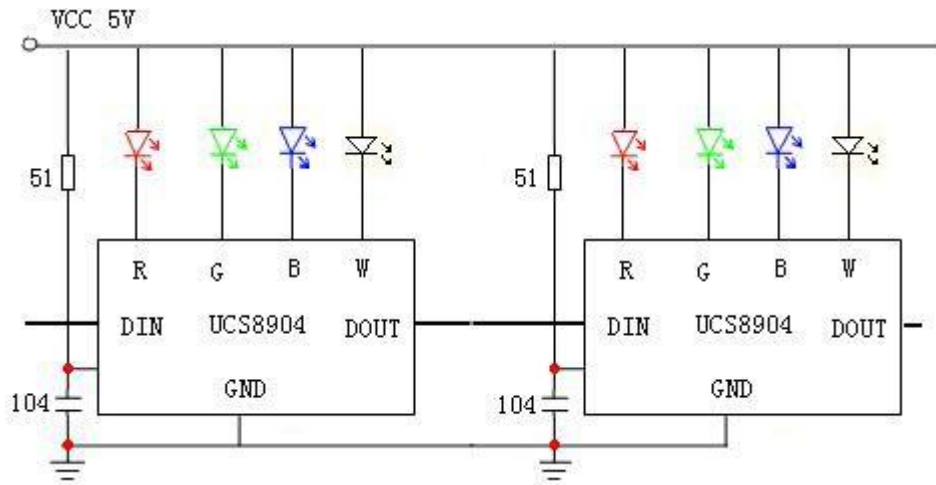

Using constant current mode can be voltage falling at the same time to achieve ideal effect of brightness and color temperature is kept constant.

2. Power voltage is 12V

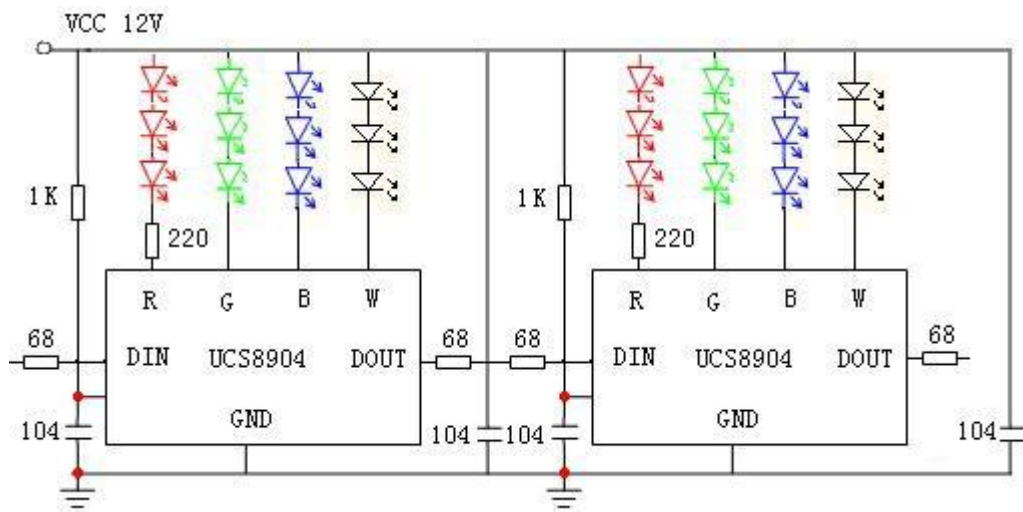

In order to prevent the damage of charged pull plug, when 12v power supply, Din and Do all the string in a 68-80 ohm resistor for protection

In order to reduce the interference, between each lamps and lanterns of power supply and ground multiple a capacitance of 104 or 105

3. Power voltage is 24V

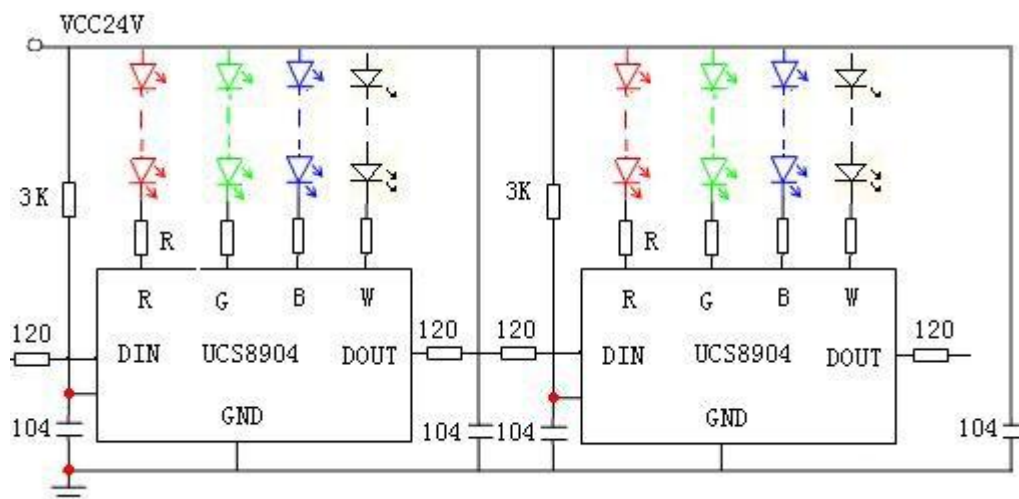

In order to prevent the damage of charged pull plug, when 24v power supply, Din and Do all the string in a 120 ohm resistor for protection

In order to reduce the interference, between each lamps and lanterns of power supply and ground multiple a capacitance of 104 or 105

4 . Power voltage is 24V

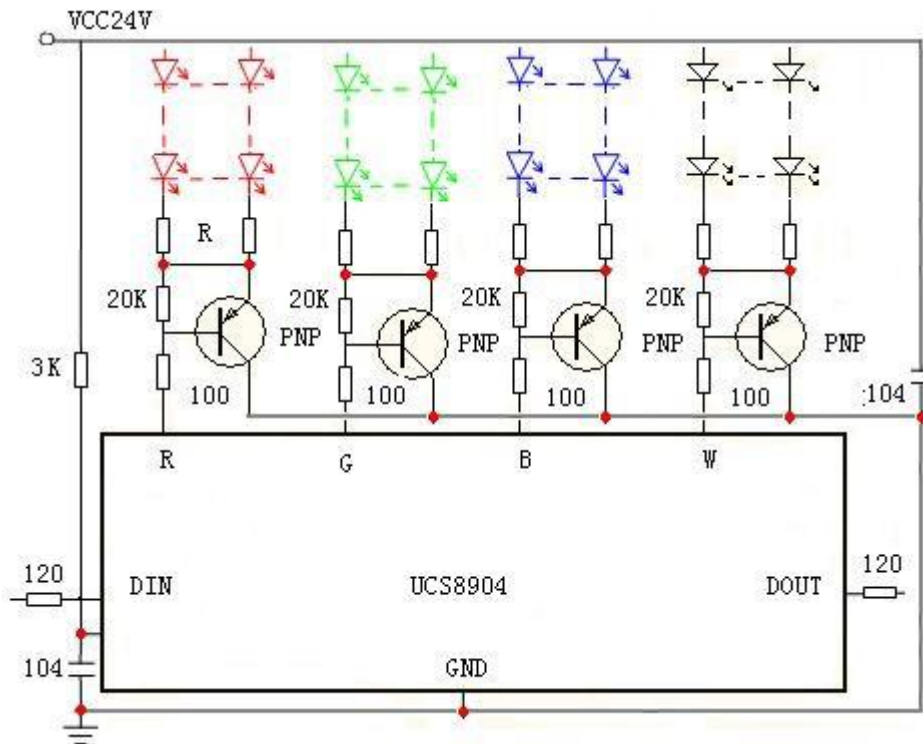

**Attention :** Shown above for the PNP transistor, 9012,8550 is work  
 In order to prevent the damage of charged pull plug, when 24 v power supply, Din and Do all the string in a 120 ohm resistor for protection  
 In order to reduce the interference, between each lamps and lanterns of power supply and ground multiple a capacitance of 104 or 105

**Vds Definition and values**

Vds is the output voltage on the RGB pin . In order to avoid more than PD, Vds is no more than 3.5 v .The following formula is Vds:

$$Vds = VCC - I * R - N * Vled$$

Attention : I is Each string on the LED current , R is the resistance of LED series , N is the LED series connection number, Vled is the LED voltage

**stabilizing voltage characteristic**

UCS2904B built-in stabilizer, according to the power supply voltage (VCC) is different, must choose different resistance (VR) for step-down voltage, Resistance to select in the table below for reference:

VCC (V)	VR(ohm)
5	51-80
12	800 - 1 K
15	1.2 K - 1.5 K
24	2.4 K - 3 K

package outline drawing and dimension

SOP8

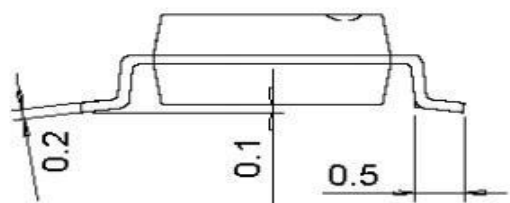
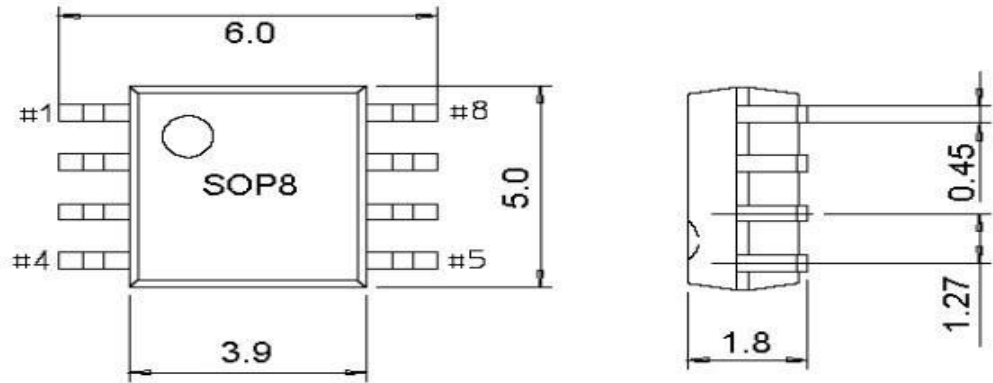

Version

versions	Issuing date	Revised profile
VER1.0	2010-2-20	The first issue
VER2.0	2011-9-11	Layout Adjustment